

Safety Checklist after first assembly

- **Test intervals of Safety: 6 months**

- **Test Component and contents:**

1. Removing the reticulated system:
 - Check of removing condition each rope
 - Screwing the turn buckle and conversion the turnbuckle in anchors plate(see for this workstep turnbuckle assembly)
2. Abrasion condition of rope:
 - Checking of all rope surface
 - Strengthened of rope: Coating on the surface
3. Attachment condition of the anchors plate and turnbuckle
4. Screwing condition of all bolt
5. Galvanizing condition of the steel component:
 - Protection of steel component from corrosion.

- **Measure**

In case of the appearance the defect detail is repaired usually within 3 days after checking.

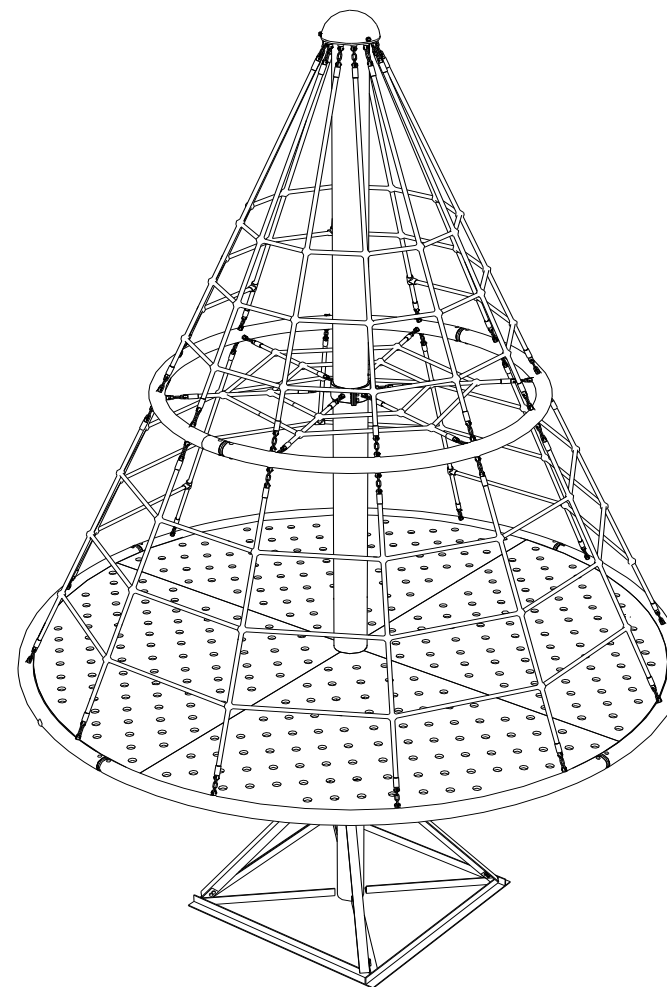

Features

The Spacecraft launches the merry-go-round into the future with a space-age look. Children love the flying-saucer design that helps their imaginations fly into orbit.

Our special bearing system controls the rotation speed so that the children can safely enjoy the same exhilarating experience as a merry-go-round.

The GS-SC2300F features GS Web Technology which includes the highest steel content and the strongest connection materials in the industry, including a steel-wire core in our edge ropes and connection points crushed in place with over 75 tons of pressure to ensure long life of the games and maximum safety for the children.

GS Web Rotating Climbers help bring movement, balance, exercise and fun back into the playground.

Ages : 5 to 12 years

Capacity : 39 children

Size : D : 10' 10" / 3.30m

H : 11' 11" / 3.63m

Use zone (EN) : D : 23' 12" / 7.30m

Use zone (ASTM) : D : 22' 10" / 6.96m

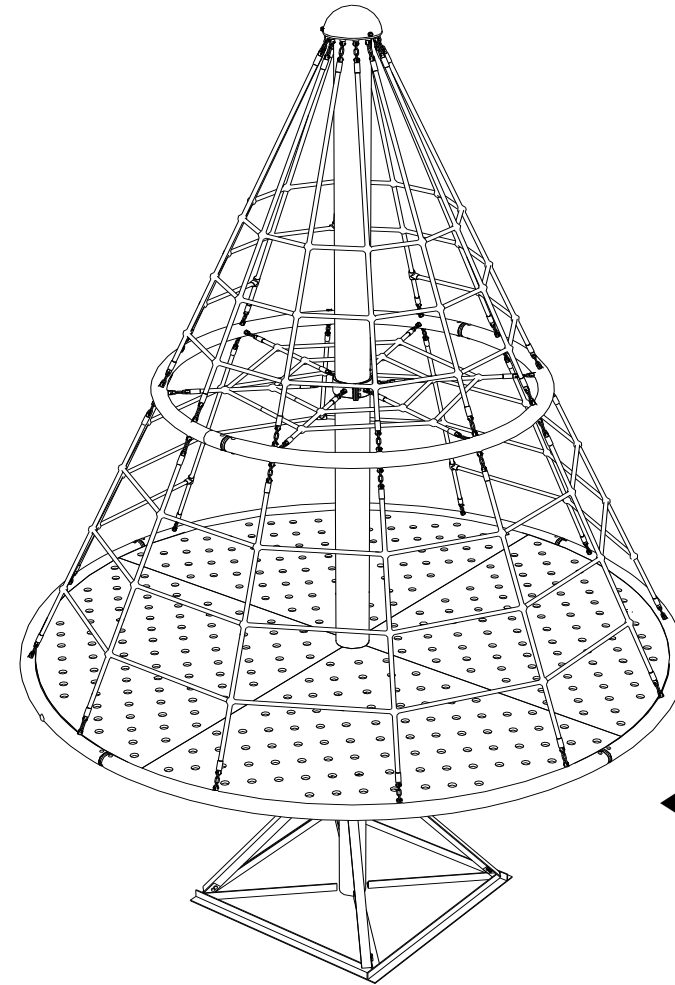

◀ **Completed Net**

Safety area

The requirements for space and safety clearances are taken from BS-EN 1176-1 / ASTM-F1487 / CSA Z614

The use zone for stationary play equipment shall extend no less than 72 in. (1830mm) from all sides of the play structure.

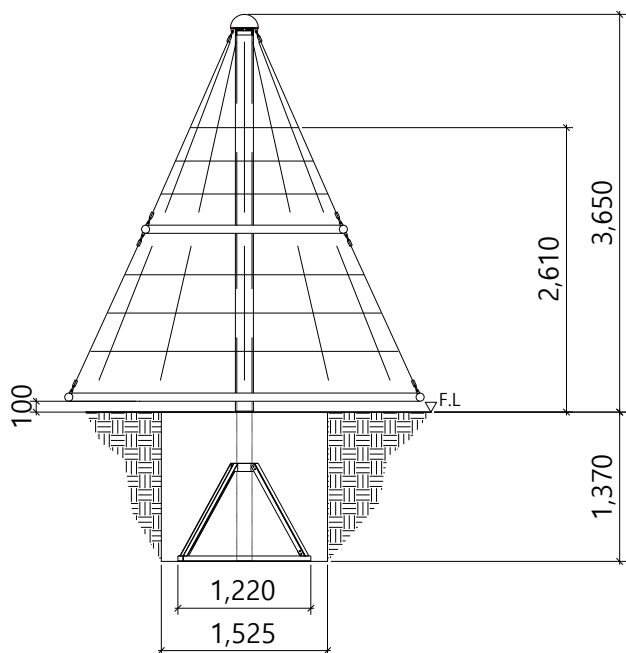
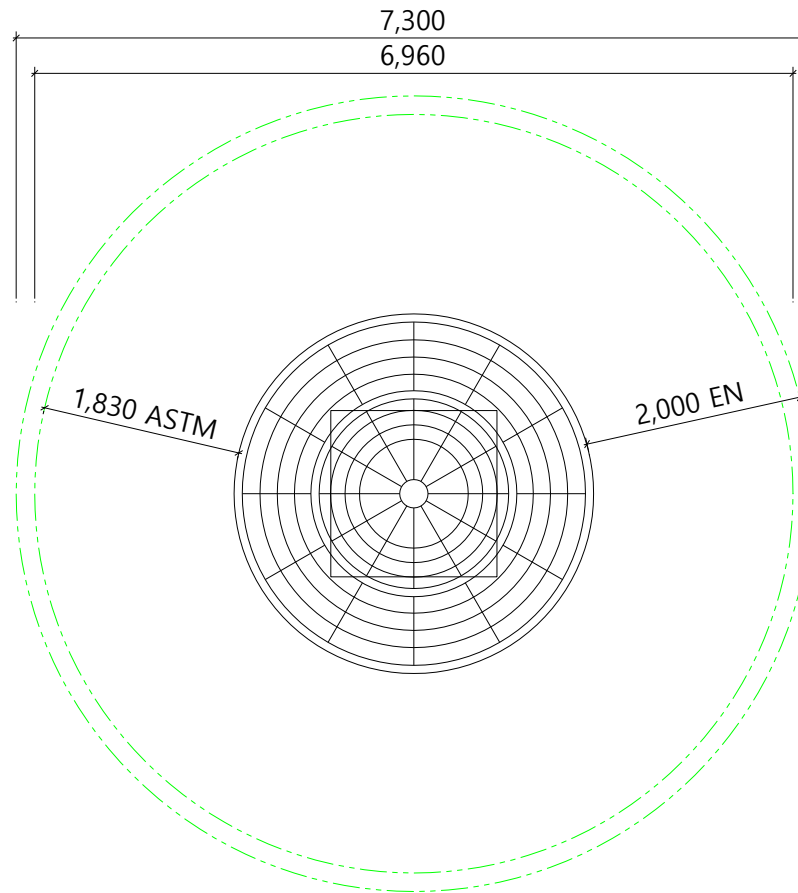
Fall Height : 2610mm (from surface)

▼ Fall Height and safety area

Foundation

Measure location and dig a hole 1525mm x 1525mm x 1370mm deep centered on the center of the spacecraft

!Attention

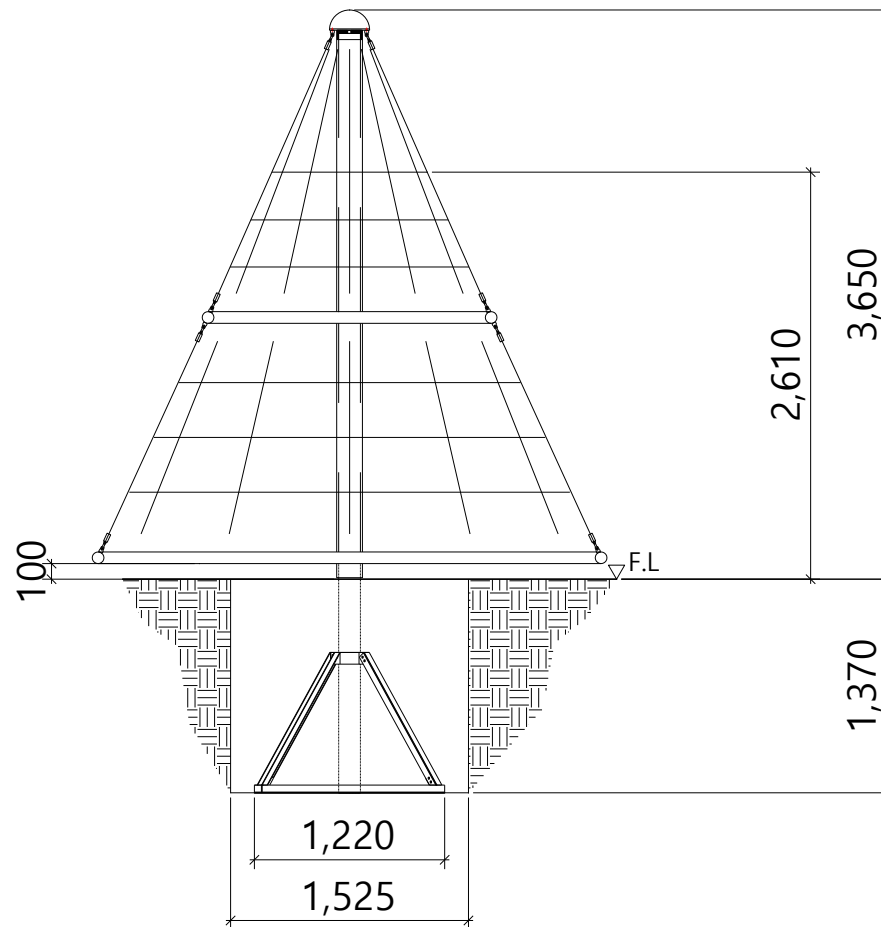
It is very important to keep a bottom of the lower ring 100 mm apart from Finished level according to safety standard.



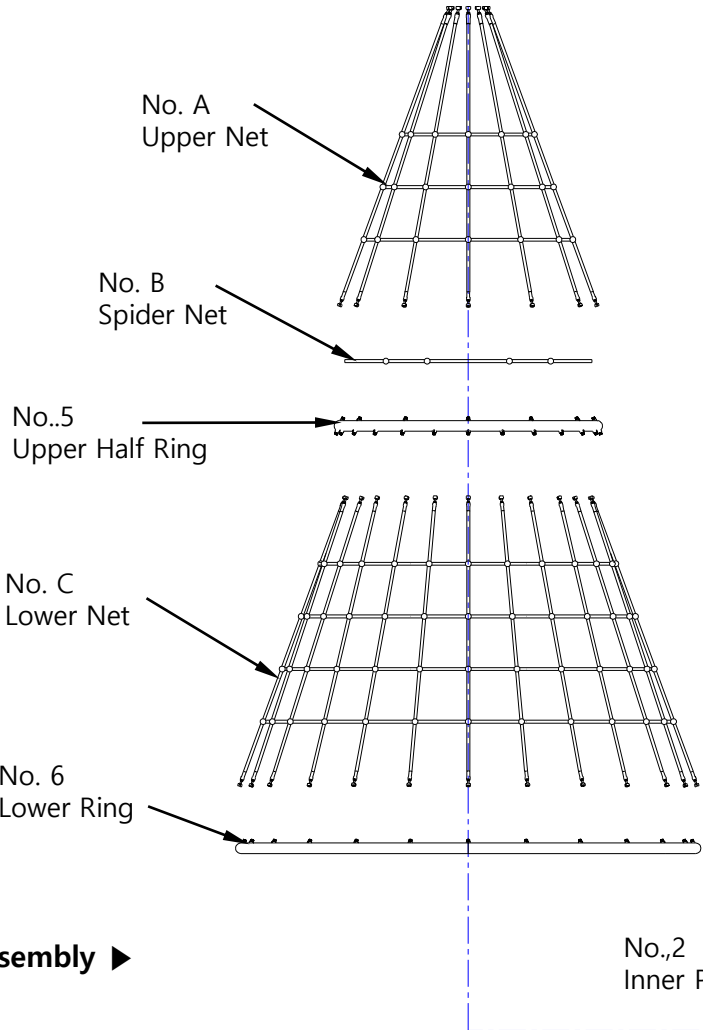

Overall Assembly ▶

Overall Assembly

Assemble the parts in the following order:

1. Attach the upper net to the post head
2. Attach the ring to the net
3. Attach the spider net to the ring and the collar
4. Attach the lower net to the ring
5. Temporarily support the lower net by tying it to the middle ring before lifting the assembly
6. Assemble base and angle braces

... cont'd next page

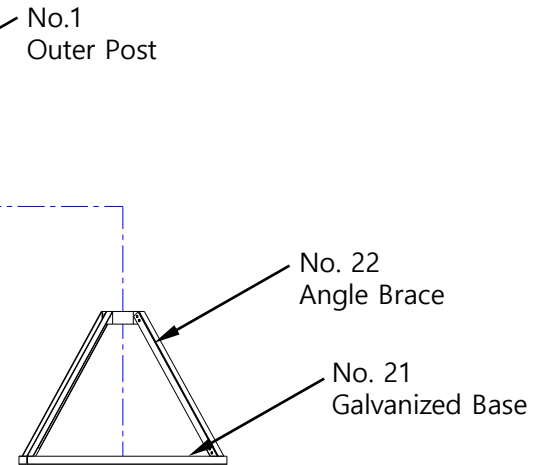

7. Screw the eye bolt to the top of the galvanized post
8. Lift the assembly and place in the hole, inserting the post into the pre-assembled base.
9. Level the post and fill hole with excavated ground
10. Install the protective surface
11. Assemble the lower ring and deck, attach to lower net.
12. Attach deck to collar on the post
- 13. Remove eye bolt** and install the cap

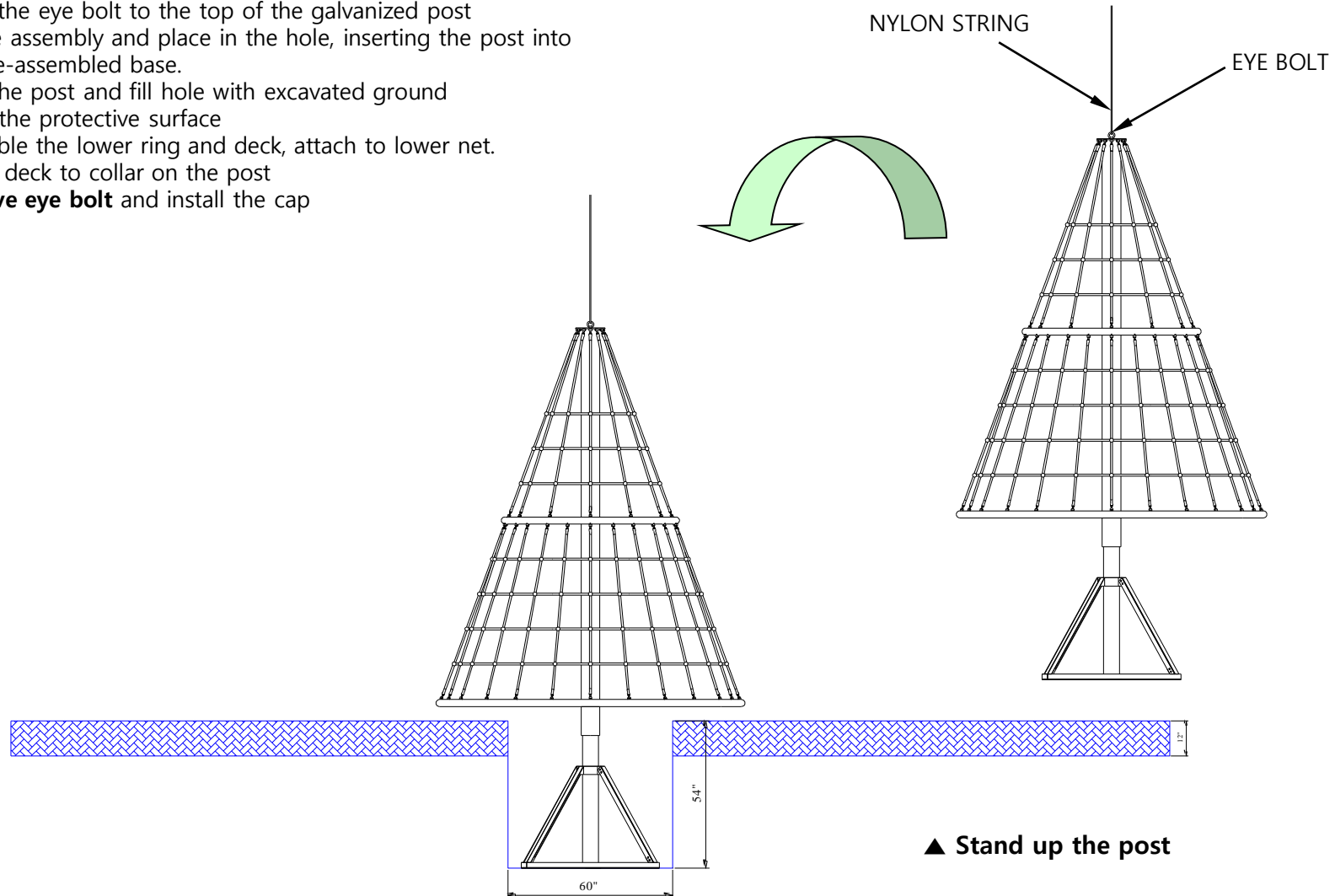

▲ Stand up the post

Assemble all parts of base as shown below

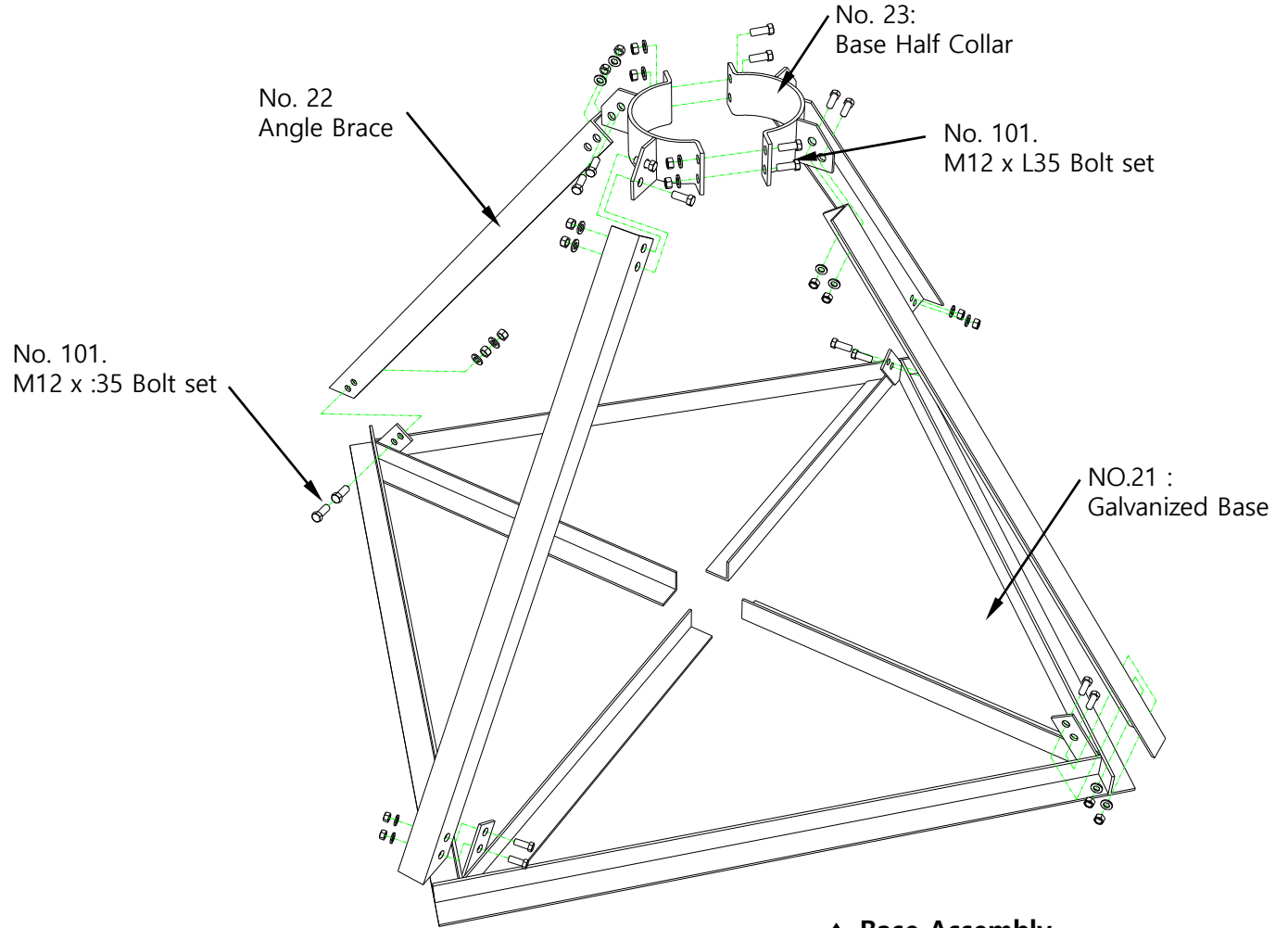

▲ Base Assembly

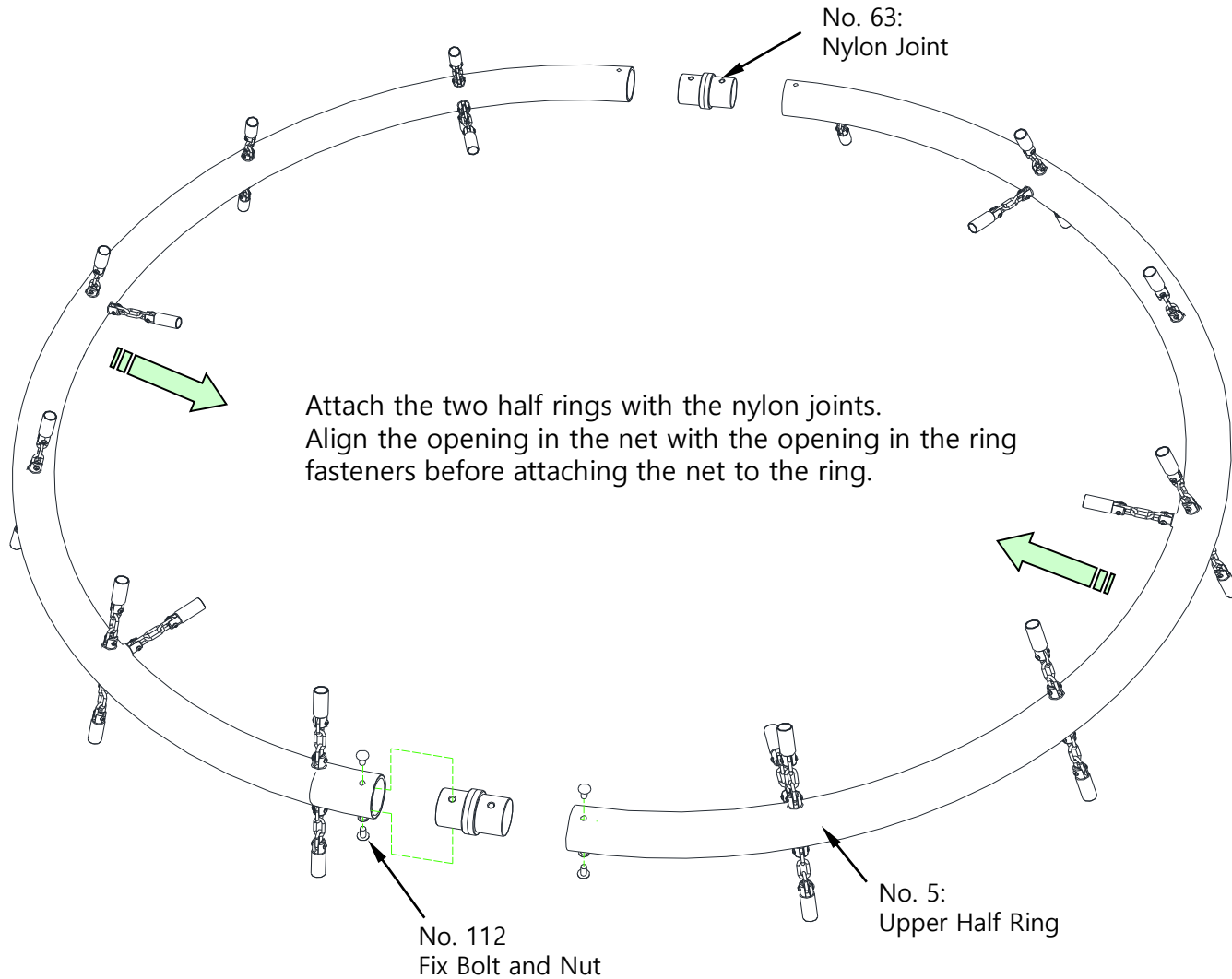

Attach the upper ring to the upper net
Attach the spider net to the upper ring and the post

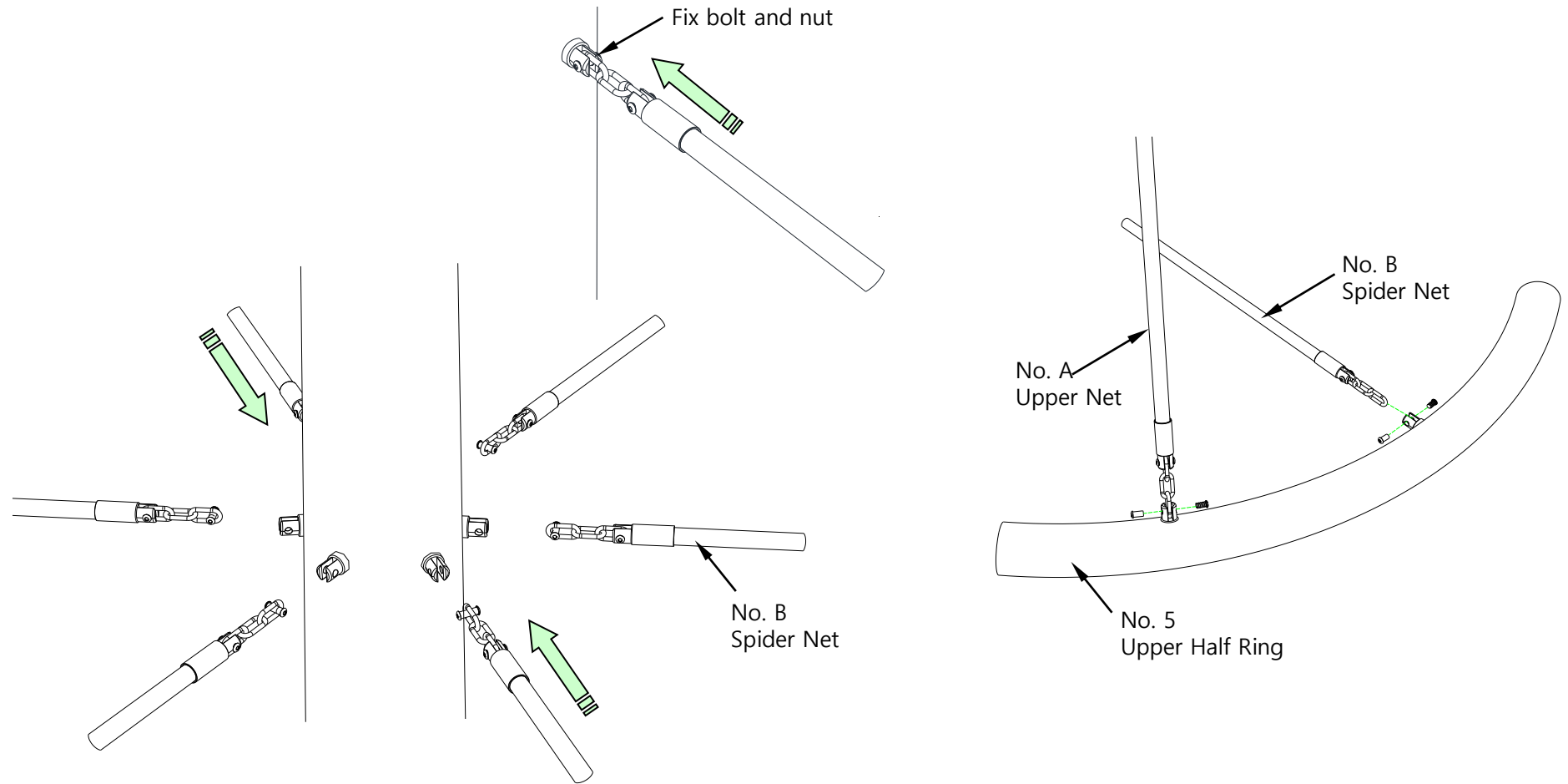

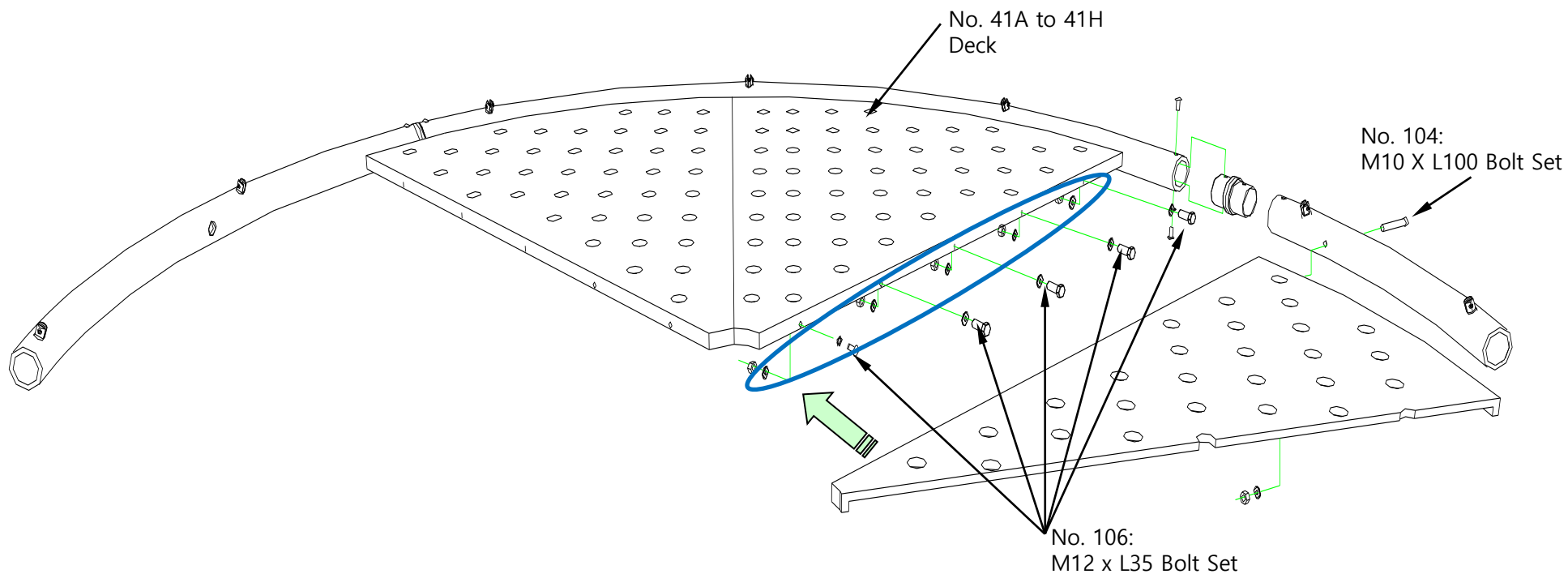

* Bottom

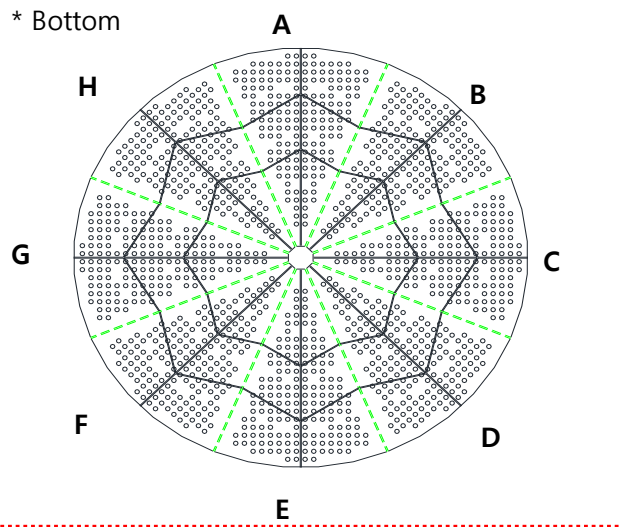

! Attention

Please follow the assembly sequence.

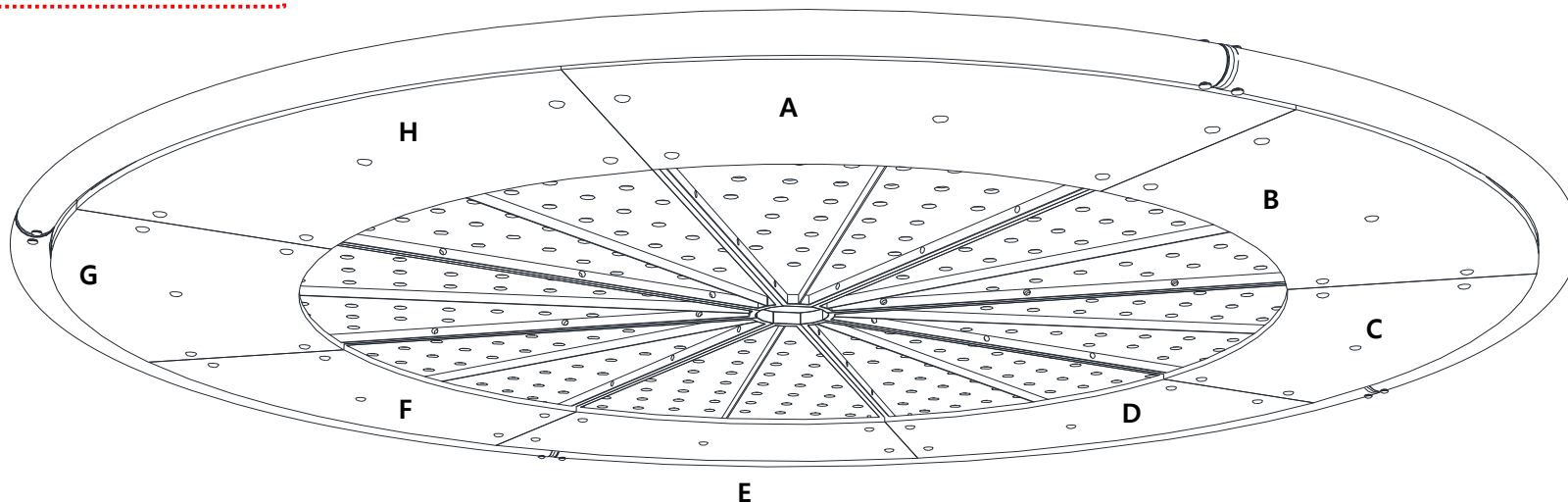

▲ **Bottom of the deck**

Assemble Deck Cover Plate like A ,B ,E and F before assembling bottom decks

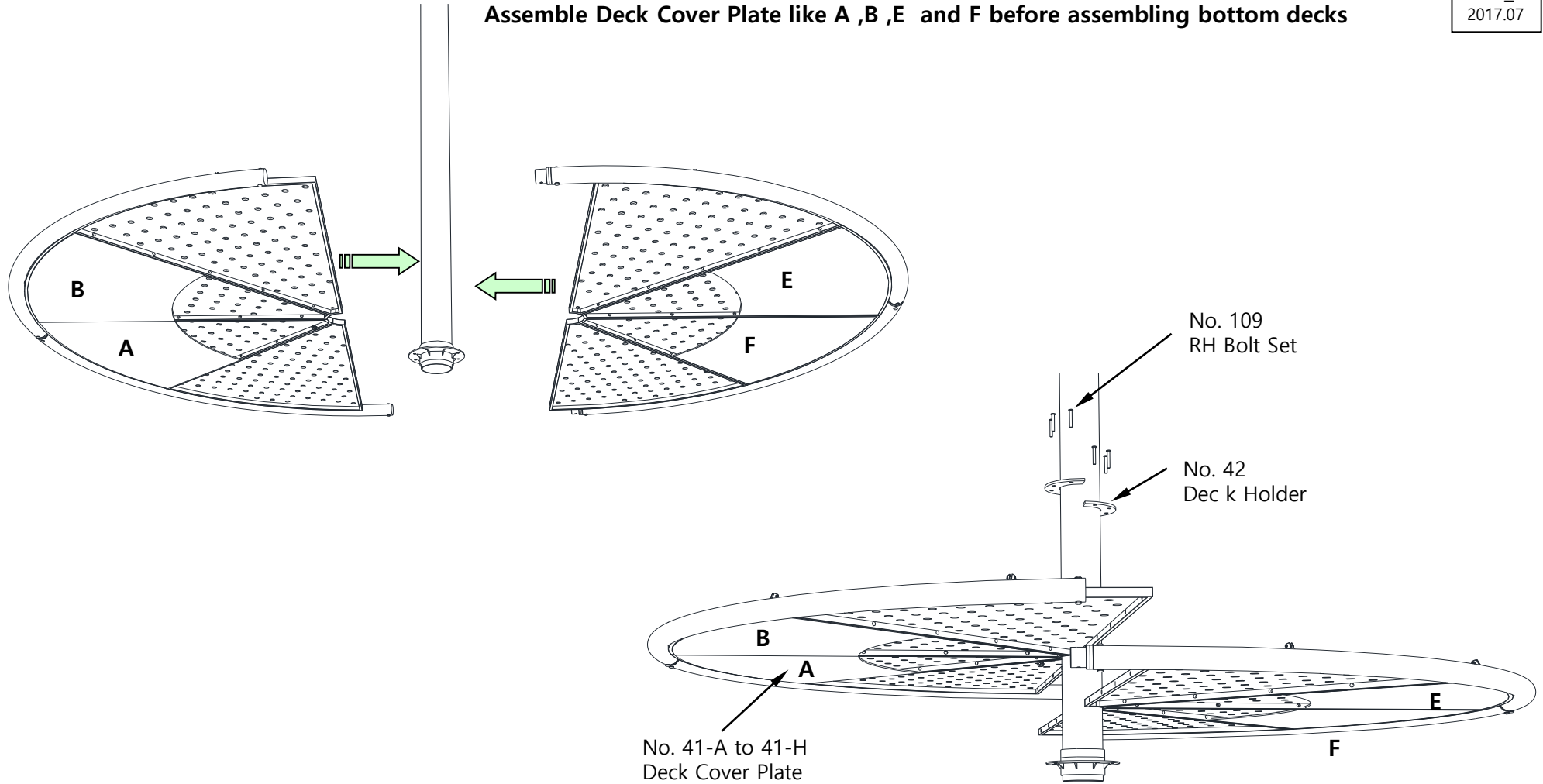

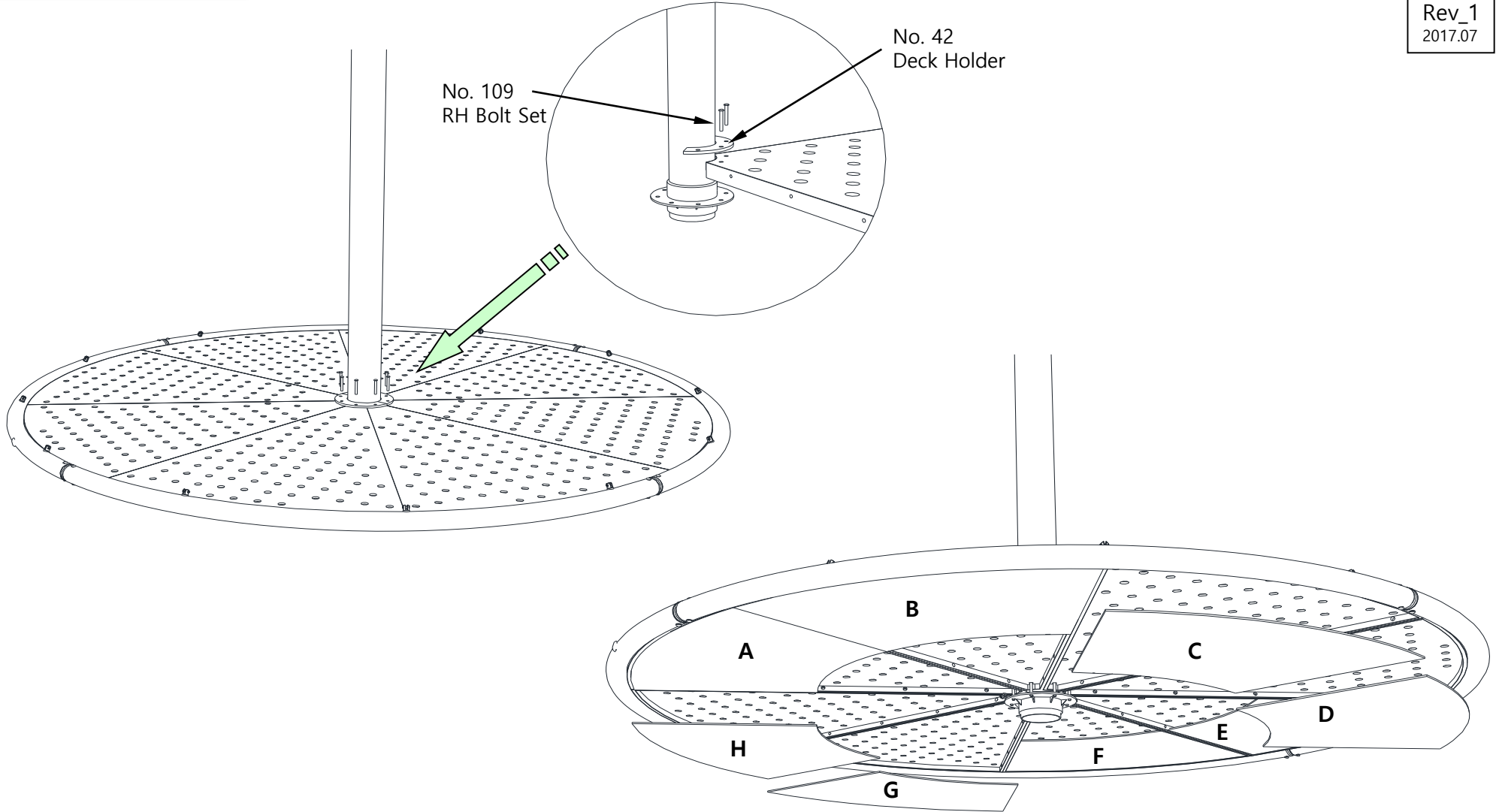

Assemble Deck Cover Plate like C,D,G and H after assembling decks

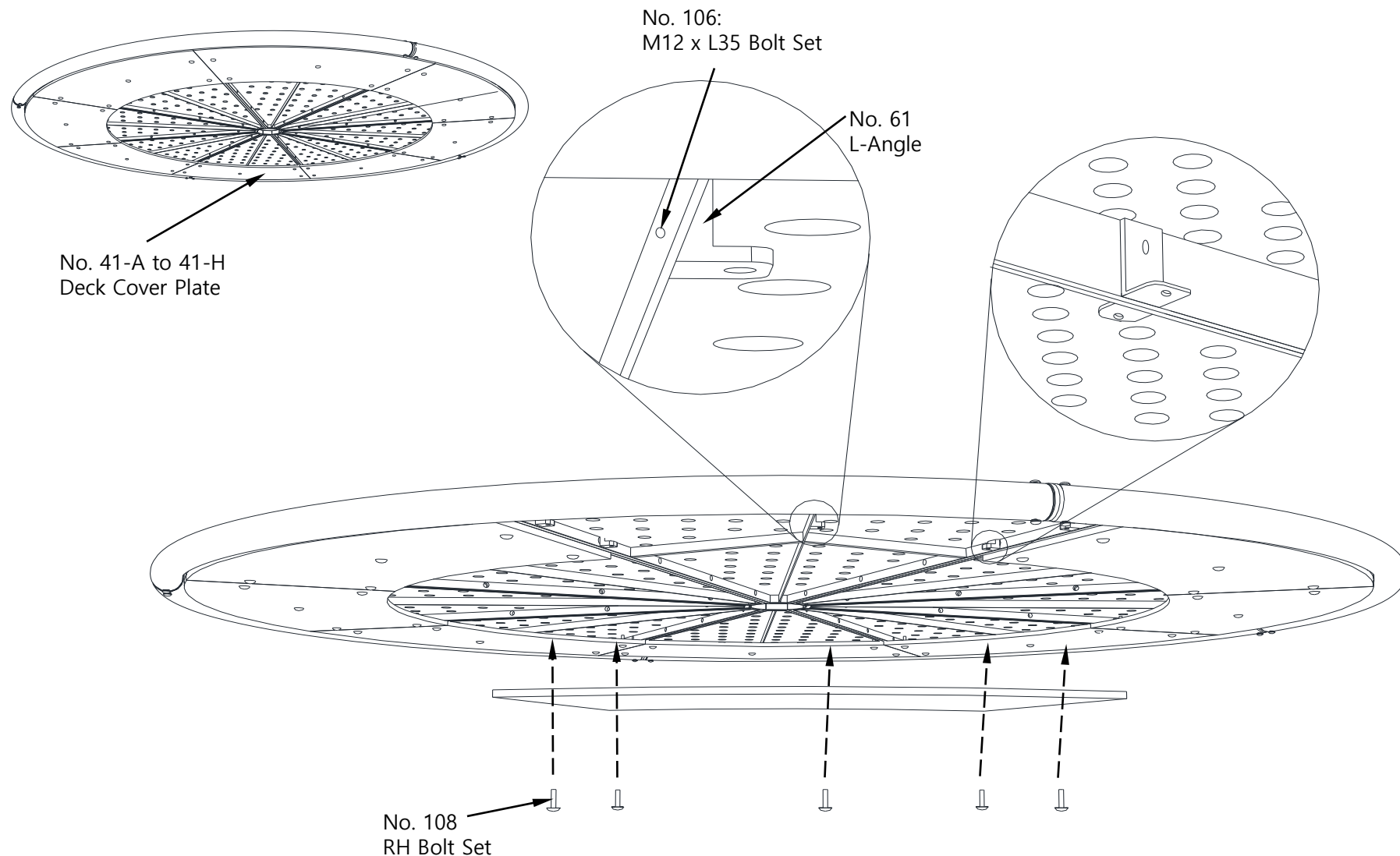

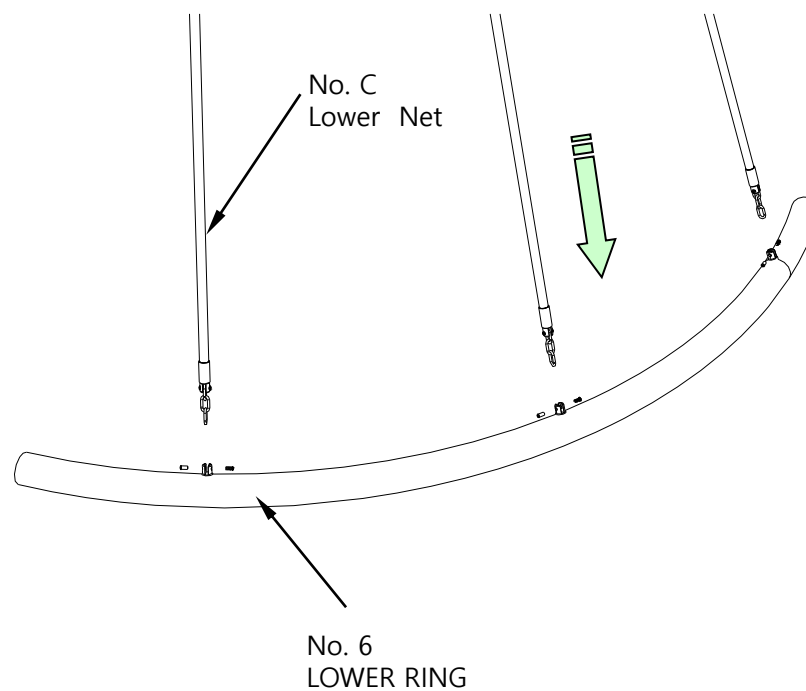
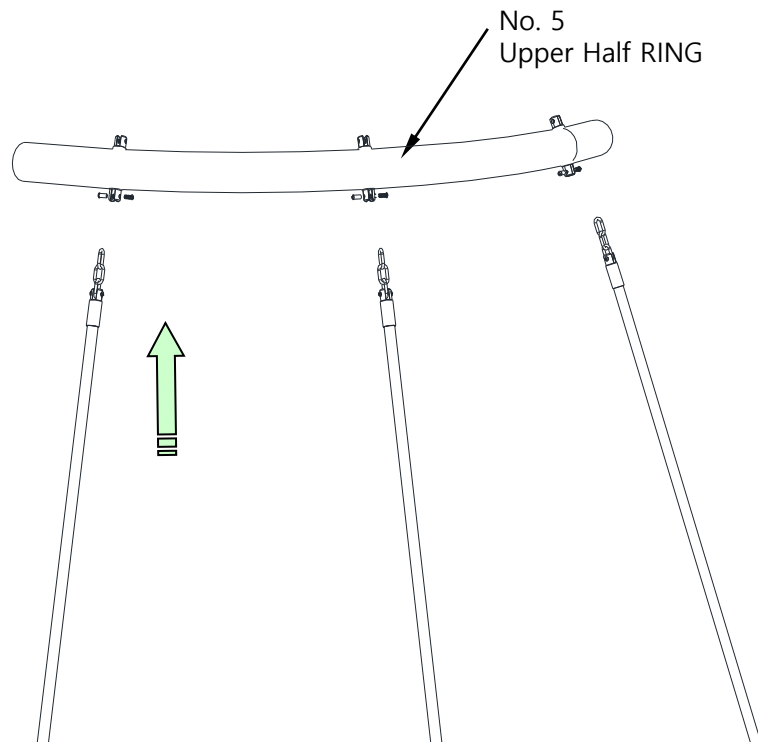
Assemble net in the attach with fix bolt and nut

Remove the eye bolt
Install the cap on the top of post

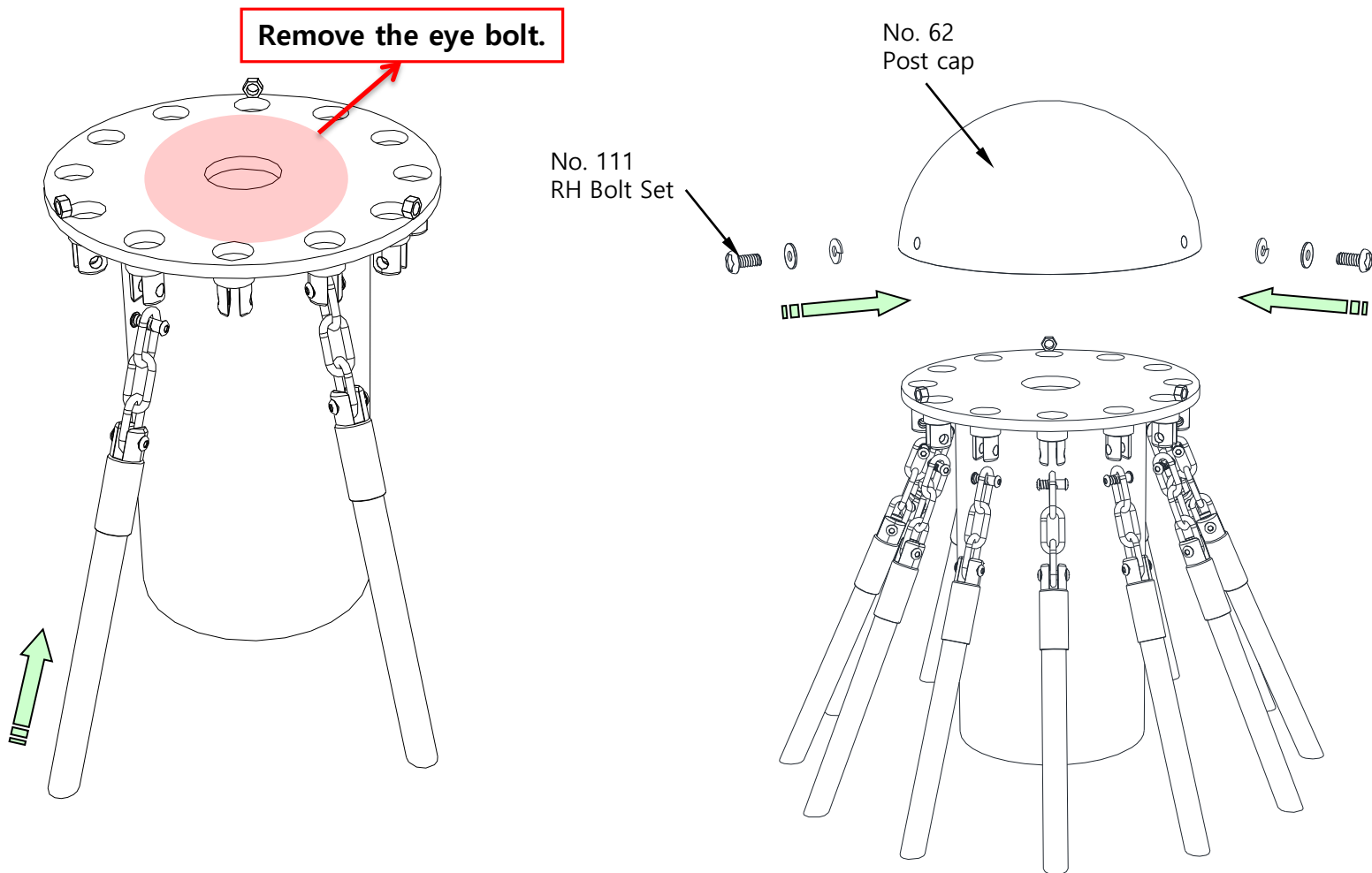

Parts check list

- A. Upper Net**
- B. Spider Net**
- C. Lower Net**
- 1. Outer Post**
- 2. Inner post**
- 5. Upper Half Ring**
- 6. Lower Ring**
- 21. Galvanized Base**
- 22. Angle Brace**
- 23. Base Half Collar**
- 41. Deck (A to H)
- 41-1. Deck Cover (A to H)
- 42. Deck Holder
- 61. L-Angle
- 62. Post Cap**
- 63. Nylon Joint

- 101. M12 x L35 Bolt Set**
- 104. M10 x L100 RH Bolt Set
- 105. M12 x L45 Bolt Set
- 106. M12 x L35 Bolt Set
- 107. M8 x L35 Bolt Set
- 108. M8 x L20 RH Bolt Set
- 109. M10 x L80 RH Bolt Set
- 110. Eye Bolt
- 111. M10 x L25 RH Bolt Set**
- 112. Fix Bolt and Nut

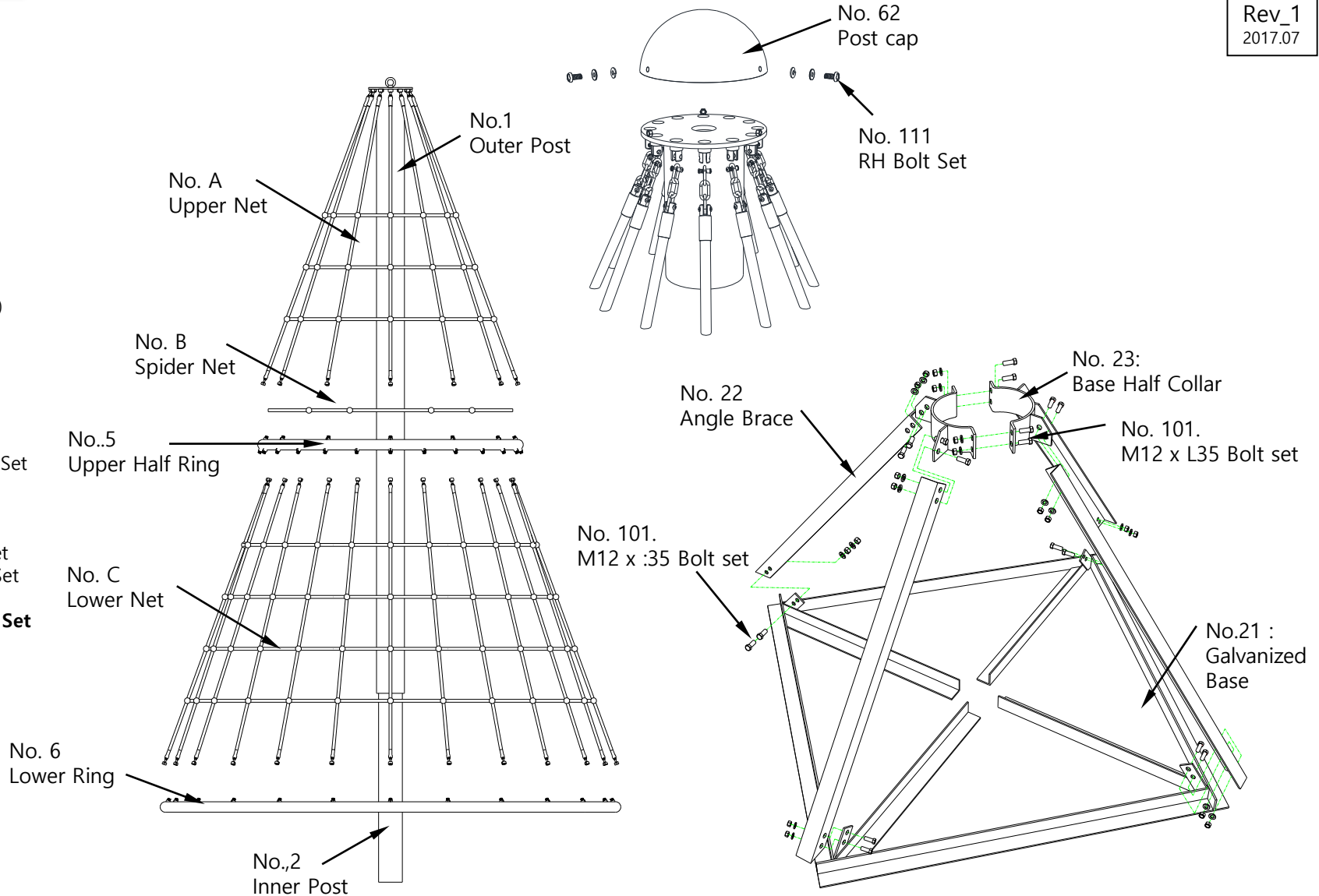

Parts check list

- A. Upper Net
- B. Spider Net
- C. Lower Net
- 1. Outer Post
- 2. Inner post
- 5. Upper Half Ring
- 6. Lower Ring
- 21. Galvanized Base
- 22. Angle Brace
- 23. Base Half Collar
- 41. Deck (A to H)**
- 41-1. Deck Cover (A to H)
- 42. Deck Holder**
- 61. L-Angle
- 62. Post Cap
- 63. Nylon Joint

- 101. M12 x L35 Bolt Set
- 104. M10 x L100 RH Bolt Set**
- 106. M12 x L35 Bolt Set**
- 108. M8 x L20 RH Bolt Set
- 109. M10 x L80 RH Bolt Set**
- 110. Eye Bolt
- 111. M8 x L25 RH Bolt Set
- 112. Fix Bolt and Nut

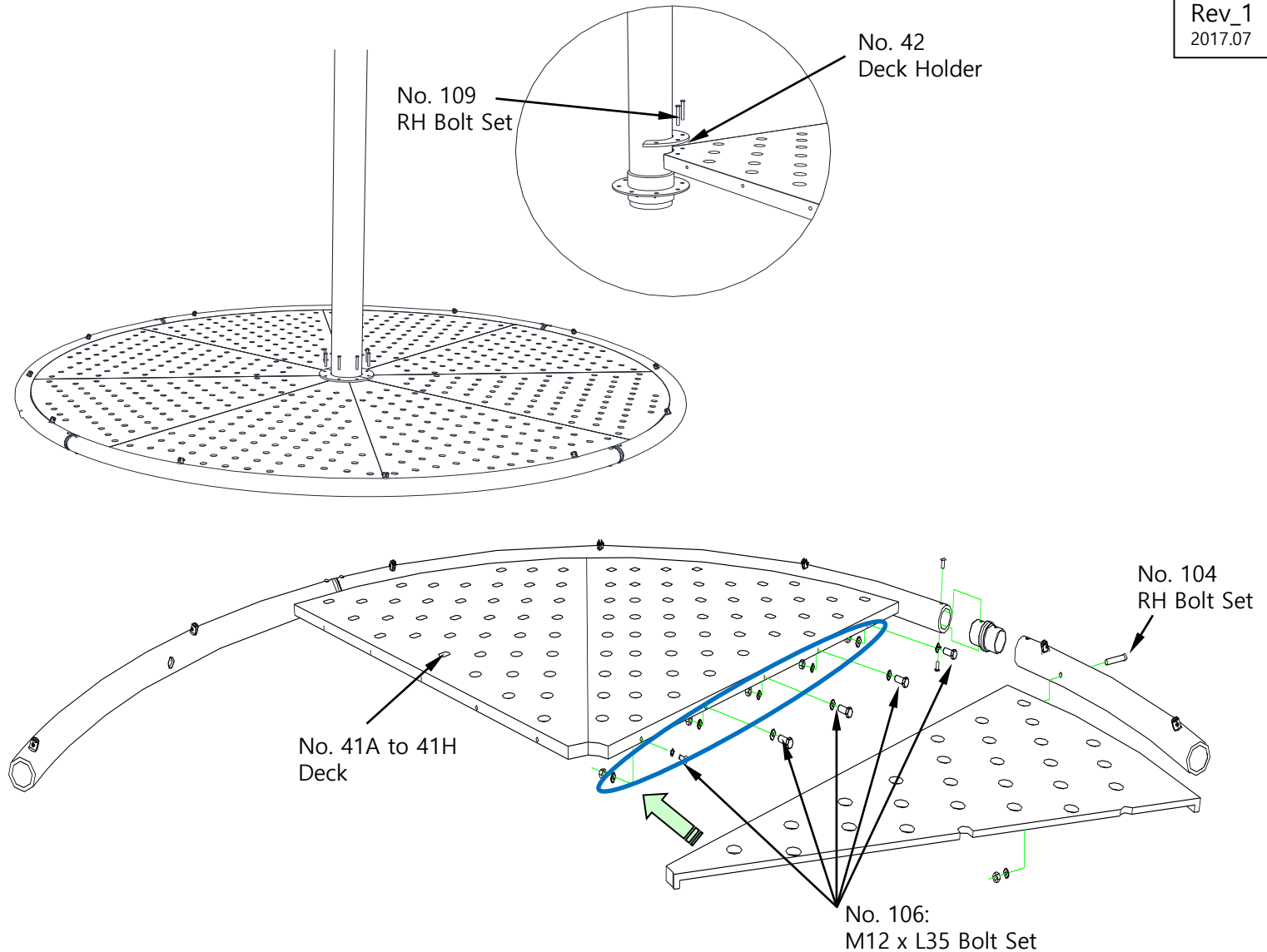

Parts check list

- A. Upper Net
- B. Spider Net
- C. Lower Net
- 1. Outer Post
- 2. Inner post
- 5. Upper Half Ring
- 6. Lower Ring
- 21. Galvanized Base
- 22. Angle Brace
- 23. Base Half Collar
- 41. Deck (A to H)
- 41-1. Deck Cover (A to H)**
- 42. Deck Holder
- 61. L-Angle**
- 62. Post Cap
- 63. Nylon Joint

- 101. M12 x L35 Bolt Set
- 104. M10 x L100 RH Bolt Set
- 106. M12 x L35 Bolt Set
- 108. M8 x L20 RH Bolt Set**
- 109. M10 x L80 RH Bolt Set
- 110. Eye Bolt
- 111. M8 x L25 RH Bolt Set
- 112. Fix Bolt and Nut

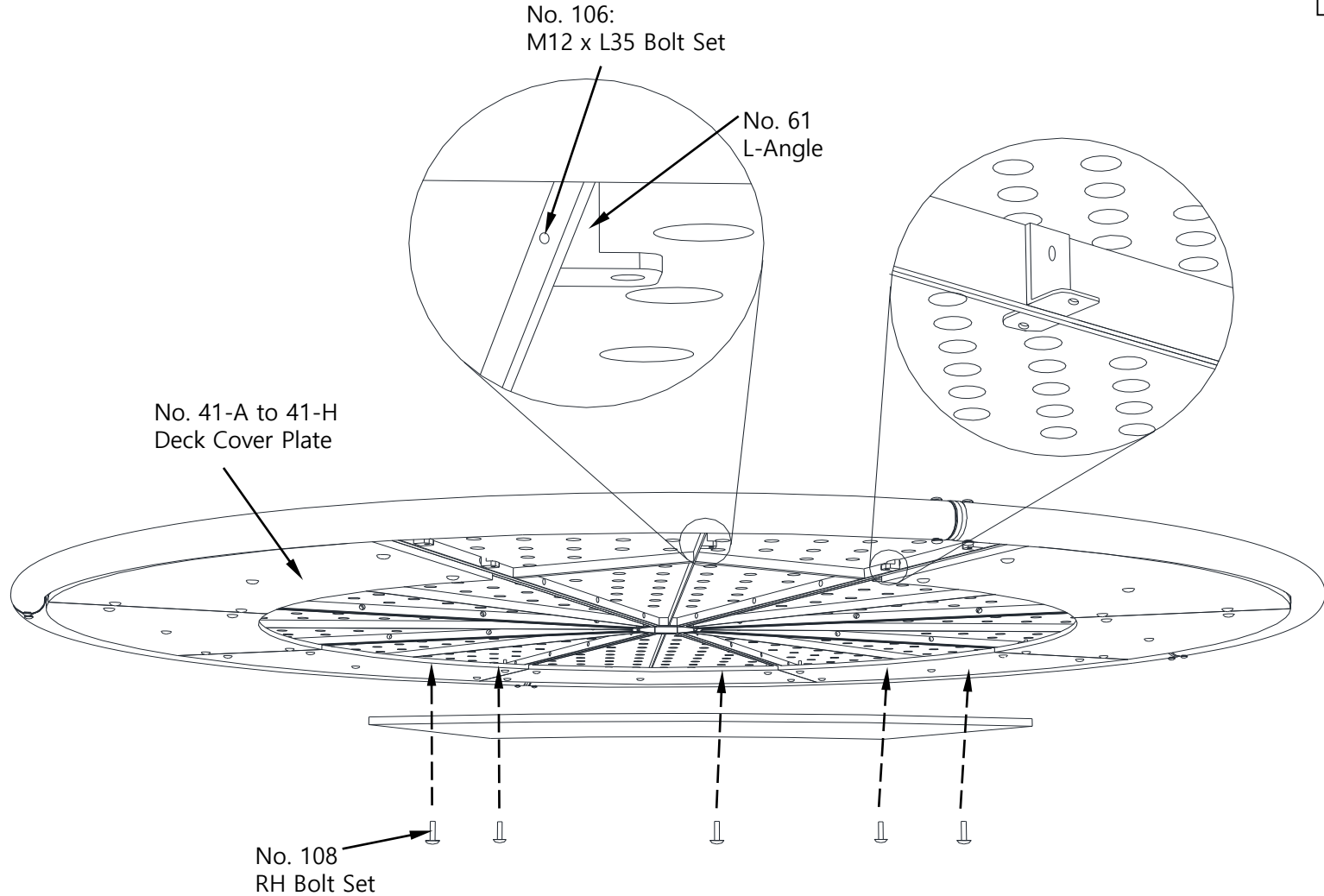

A. General safety measures

On the playground there should be a sign(pictogram) giving the following information:

- a) general emergency telephone number;
- b) telephone number to contact maintenance personnel;
- c) name of the playground;
- d) address of playground; and
- e) other relevant local information, if applicable.

The entry, exit and emergency paths to and from a playground, intended for use by the public and emergency services, should be accessible and free of obstacles at all times.

NOTE Attention is drawn to local regulations.

B. Procedures

Defects that occur during operation and which put safety at risk should be corrected without delay. If this is not possible, the equipment should be secured against use e.g. by immobilization or removal.

There should be written operational procedures covering the measures to be taken in the event of accidents, fire and the like.

Until unsafe equipment is repaired and released for use, access by the public should be prevented. Information about accidents brought to the attention of the manager should be recorded on a form that includes the following details:

- a) date and time of accident;
- b) age and sex of victim and clothing worn, including footwear;
- c) equipment involved;
- d) number of children on site at the time of the accident;
- e) description of accident;
- f) injury sustained including part(s) of body affected;
- g) action taken;
- h) witness statements;
- i) any subsequent equipment modification;
- j) weather conditions; and
- k) any other relevant information.

C. Routine maintenance

To reduce accidents, the owner or operator should ensure that an appropriate routine maintenance schedule is established, implemented and maintained. This should take into account local conditions and the manufacturer's instructions that can affect the necessary inspection frequency. The schedule should list the components to be maintained and should also give procedures for dealing with complaints and breakdowns.

The routine maintenance of playground equipment and surfaces should consist of preventative measures to maintain their level of safety, performance and compliance with the relevant part(s) of EN 1176. Such measures should include:

- a) tightening of fastenings;
- b) re-painting and re-treatment of surfaces;
- c) maintenance of any impact attenuating surfaces;
- d) lubrication of bearings;
- e) marking of equipment to signify loose fill finished surface level;
- f) cleaning;
- g) removal of broken glass and other debris or contaminants;
- h) restoring loose fills to the correct level; and
- i) maintenance of free space areas.

D. Corrective maintenance

Corrective maintenance should include measures to correct defects, or to re-establish the necessary levels of safety of the playground equipment and surfaces. Such measures should include:

- a) replacement of fastenings;
- b) welding of welding repairs;
- c) replacement of worn or defective parts; and
- d) replacement of defective structural components.

E. Personal safety

Repairs during operation that could put the safety of maintenance personnel of the public at risk, should be avoided.

F. Equipment alterations

Alterations to parts of a piece of equipment or structure that could affect the essential safety of the equipment should only be carried out after consultation with the manufacturer or a competent person.