

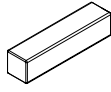

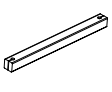

① 707210	PCS	② 707213	PCS
	8		2
118x118x503		118x118x1490	
③ 707517	PCS	④ 708346	PCS
	4		4
118x118x1892		118x118x1736	
⑤ 708522	PCS	⑥ 708688	PCS
	2		2
118x118x2139		118x118x2279	
⑦ 708721	PCS	⑧ 708722	PCS
	1		1
15x745x1766		15x745x2280	
⑨ 708836	PCS	⑩ 708837	PCS
	2		1
15x745x1736		15x745x2168	

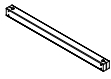

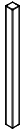

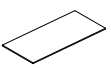
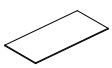
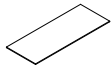
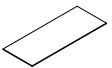
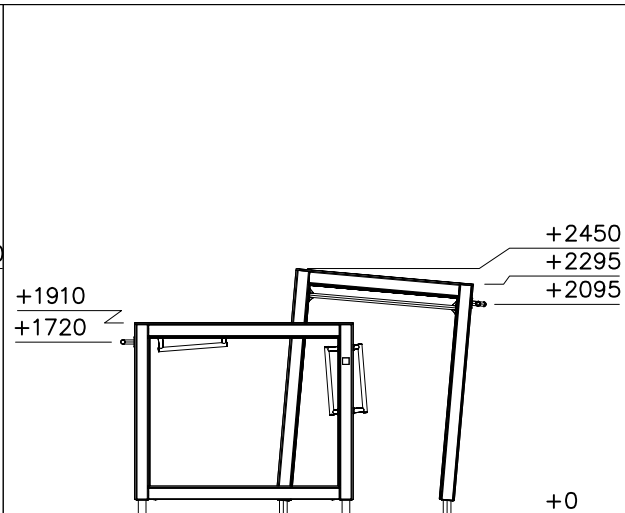
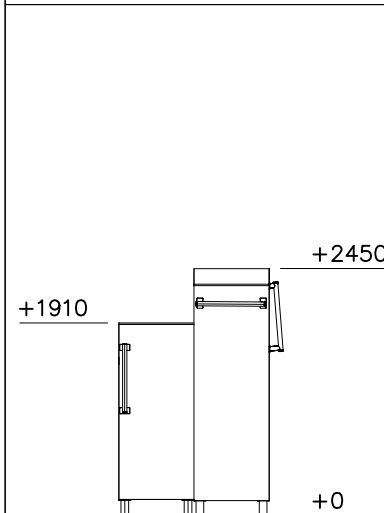
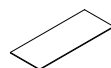
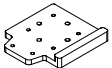
⑪ 708839	PCS	⑫ 708857	PCS
	1		1
15x745x1897		20x133x149	
⑬ 900240	PCS	⑭ 903093	PCS
	120		24
Ø8x70		Ø8x90	

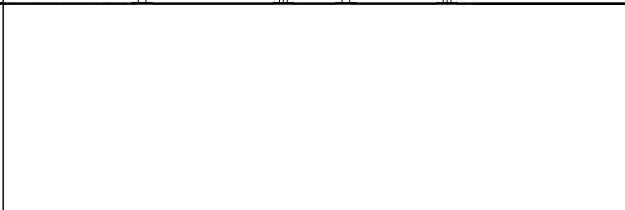
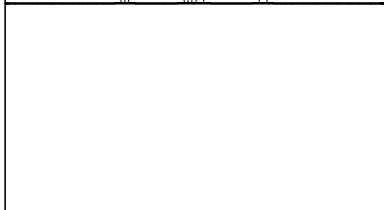
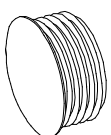
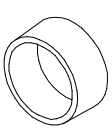



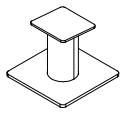
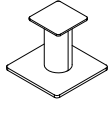





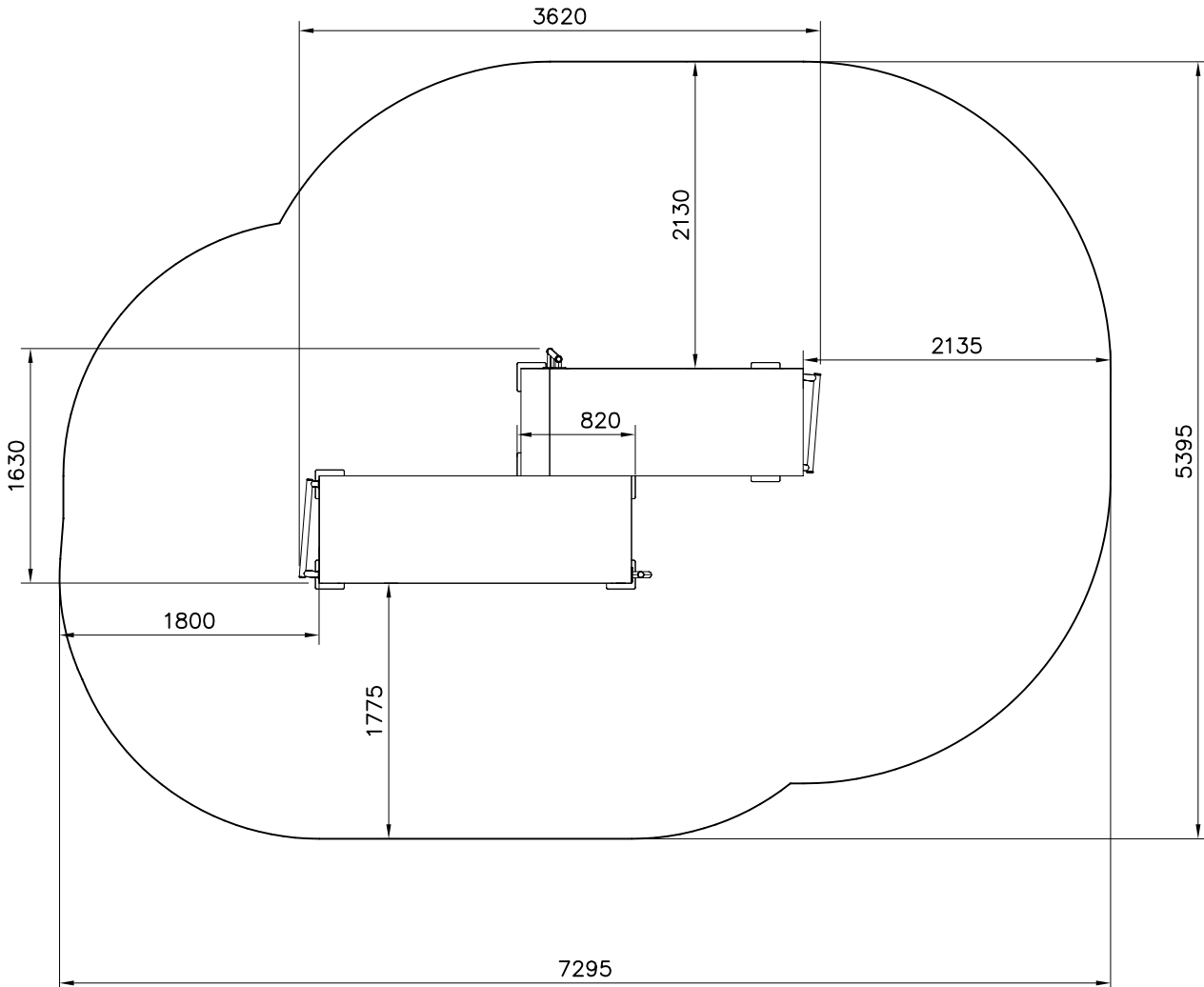
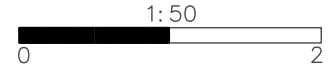

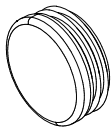
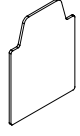

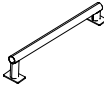
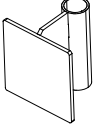

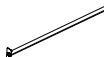
⑮ 905103	PCS	⑯ 905112	PCS
	16		24
PT-28/32-H		Ø22	

### FOOT OPTIONS

709261+		709261+		709262+	
○ 910267	PCS	○ 910330	PCS	○ 910567	PCS
SURFACE	4	SURFACE	4	CONCRETE	8
					
152x200x200		152x200x200		117x117x715	

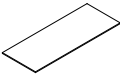
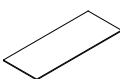
- EN Impact Attenuating Surface (IAS) 32.7 m<sup>2</sup>
- - - Falling Space 32.7 m<sup>2</sup>  
Max Falling Height 2450 mm

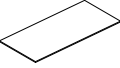

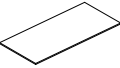
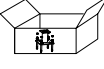
<p>①⑦ 908371 PCS 12</p>  <p>42-38/40</p>	<p>①⑧ 908698 PCS 16</p>  <p>3x114x108</p>	<p>③③ 980114 PCS 4</p>  <p>Ø4x20</p>
<p>①⑨ 910056 PCS 6</p>  <p>140x690</p>	<p>②① 910266 PCS 12</p>  <p>90x108x118</p>	<p>③④ 905086 PCS 3</p>  <p>Ø44/13.5x3.9</p>
<p>②① 910328 PCS 2</p>  <p>L 1466</p>	<p>②② 980100 PCS 21</p>  <p>Ø5x60</p>	<p>③⑤ 909248 PCS 1</p>  <p>M12</p>
<p>②③ 980123 PCS 121</p>  <p>Ø7x60</p>	<p>②④ 702286 PCS 1</p>  <p>65x65</p>	<p>③⑥ 909132 PCS 1</p>  <p>M12x280</p>
<p>②⑤ 911288 COLOR PCS 2</p>  <p>15x745x1465</p>	<p>②⑥ 911289 COLOR PCS 1</p>  <p>15x745x1897</p>	
<p>②⑦ 909225 PCS 1</p>  <p>Ø12x180</p>	<p>②⑧ 911297 MURAL PCS 1</p>  <p>12x745x2140</p>	
<p>②⑨ 911293 COLOR PCS 1</p>  <p>15x745x2145</p>	<p>③① 911295 COLOR PCS 1</p>  <p>15x745x2004</p>	
<p>③① 911301 COLOR PCS 1</p>  <p>15x745x1495</p>	<p>③② 709261 PCS 8</p> 	

DET 1

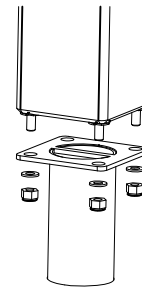

DET 2

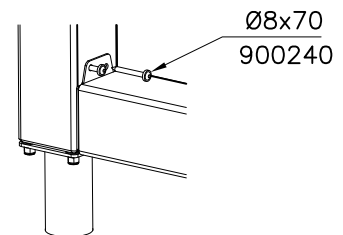
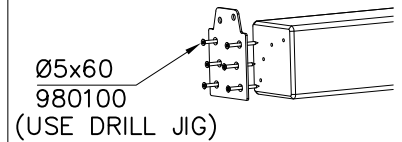

DET 3

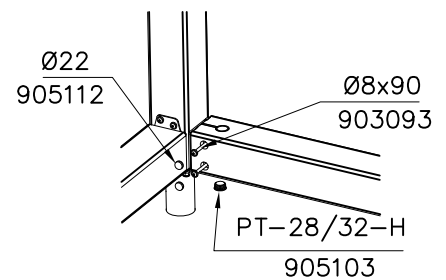
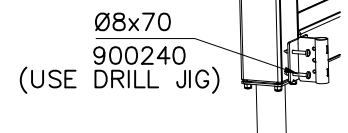

DET 4

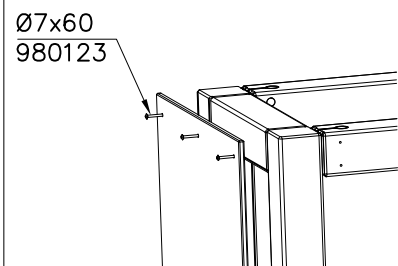

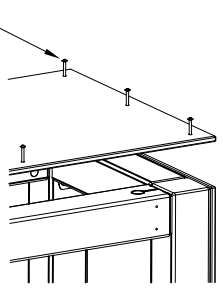
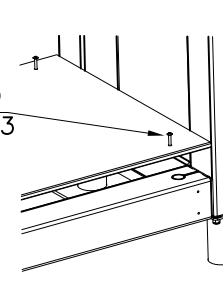
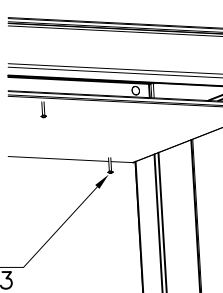
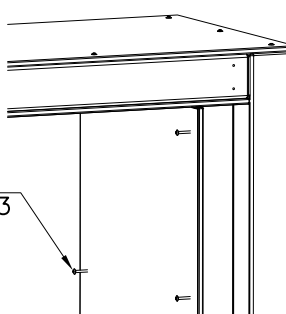
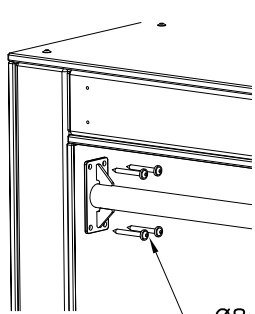
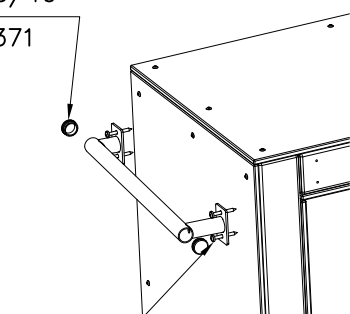
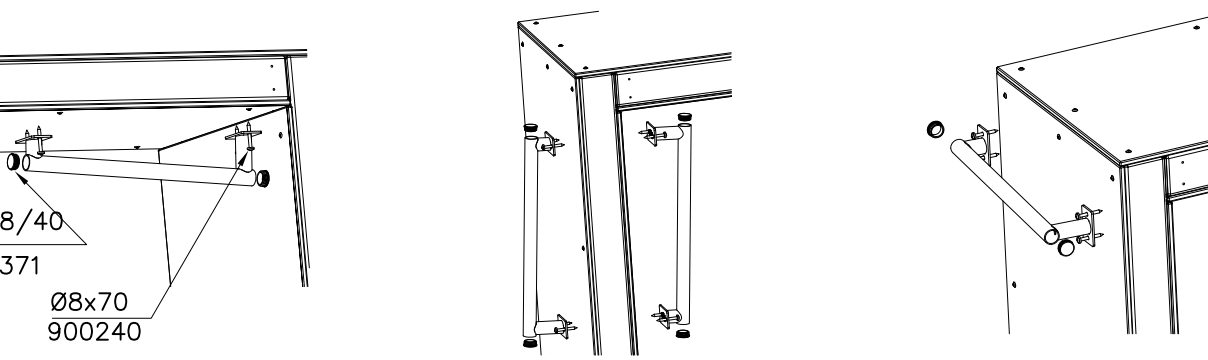
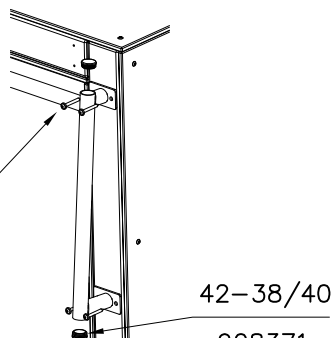
<p>DET 5</p> <p>Ø7x60 980123</p> 	<p>DET 6</p> <p>Ø7x60 980123</p> 	<p>DET 7</p> <p>Ø7x60 980123</p> 
<p>DET 8</p> <p>Ø7x60 980123</p> 	<p>DET 9</p> <p>Ø8x70 900240</p> 	<p>DET 10</p> <p>42-38/40 908371</p> <p>Ø8x70 900240</p> 
<p>DET 11 DRILL PREHOLES BEFORE INSTALLING HANDLES</p> 		
<p>DET 12 DRILL PREHOLES BEFORE INSTALLING HANDLES</p> 		

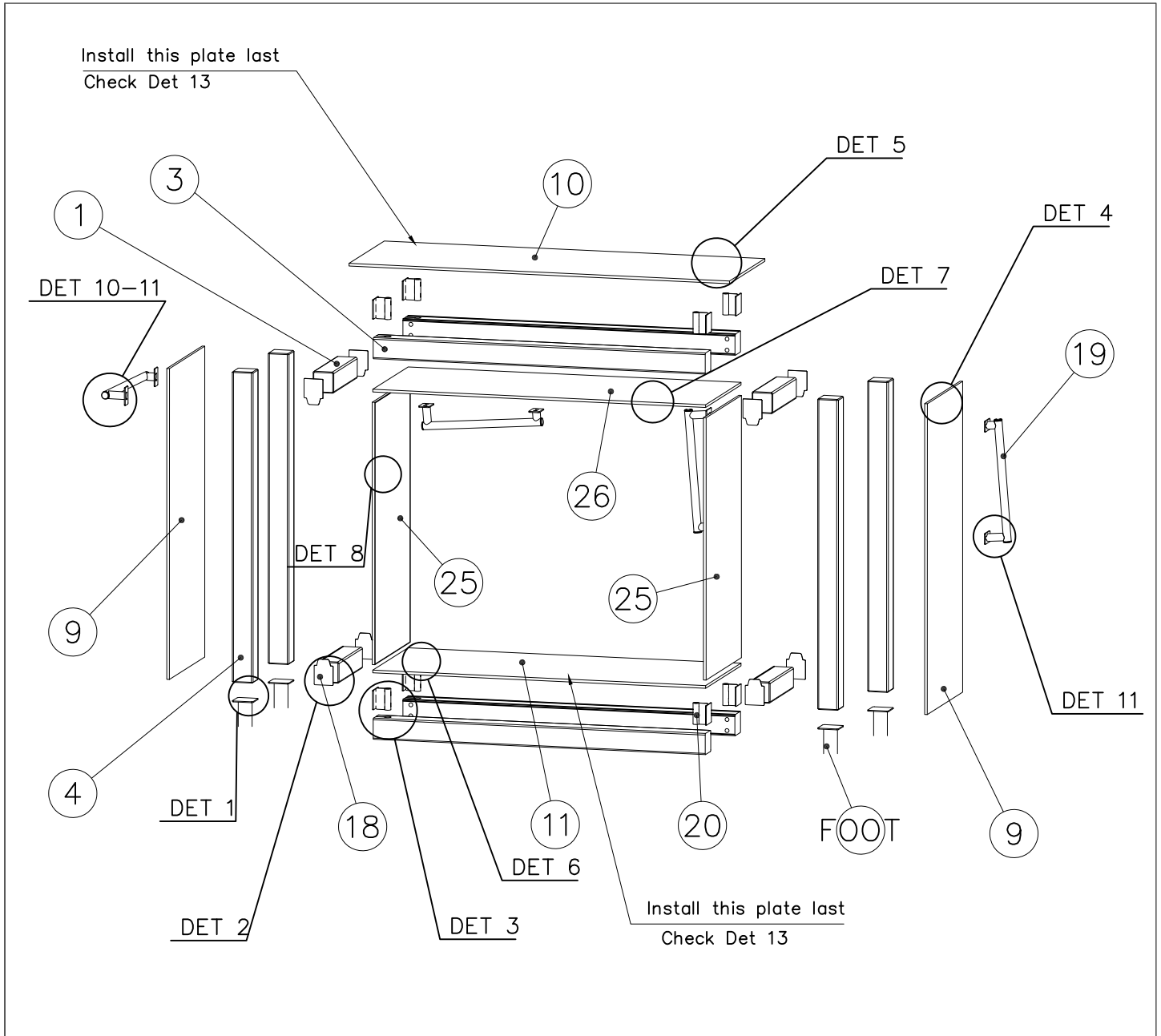

### JIG DET A (USE DET 2-3)

**NOTE:**

Use drill jig 708857 to predrill  $\varnothing 5 \nabla 50$  holes for 910266 and 908698

708857

910266

908698

$\varnothing 5 \nabla 50$

### JIG DET B (USE DET 10-11)

Plywood

Frame

708857

910056

$\varnothing 8 \times 70$   
(900240)

$\varnothing 8 \nabla 15$

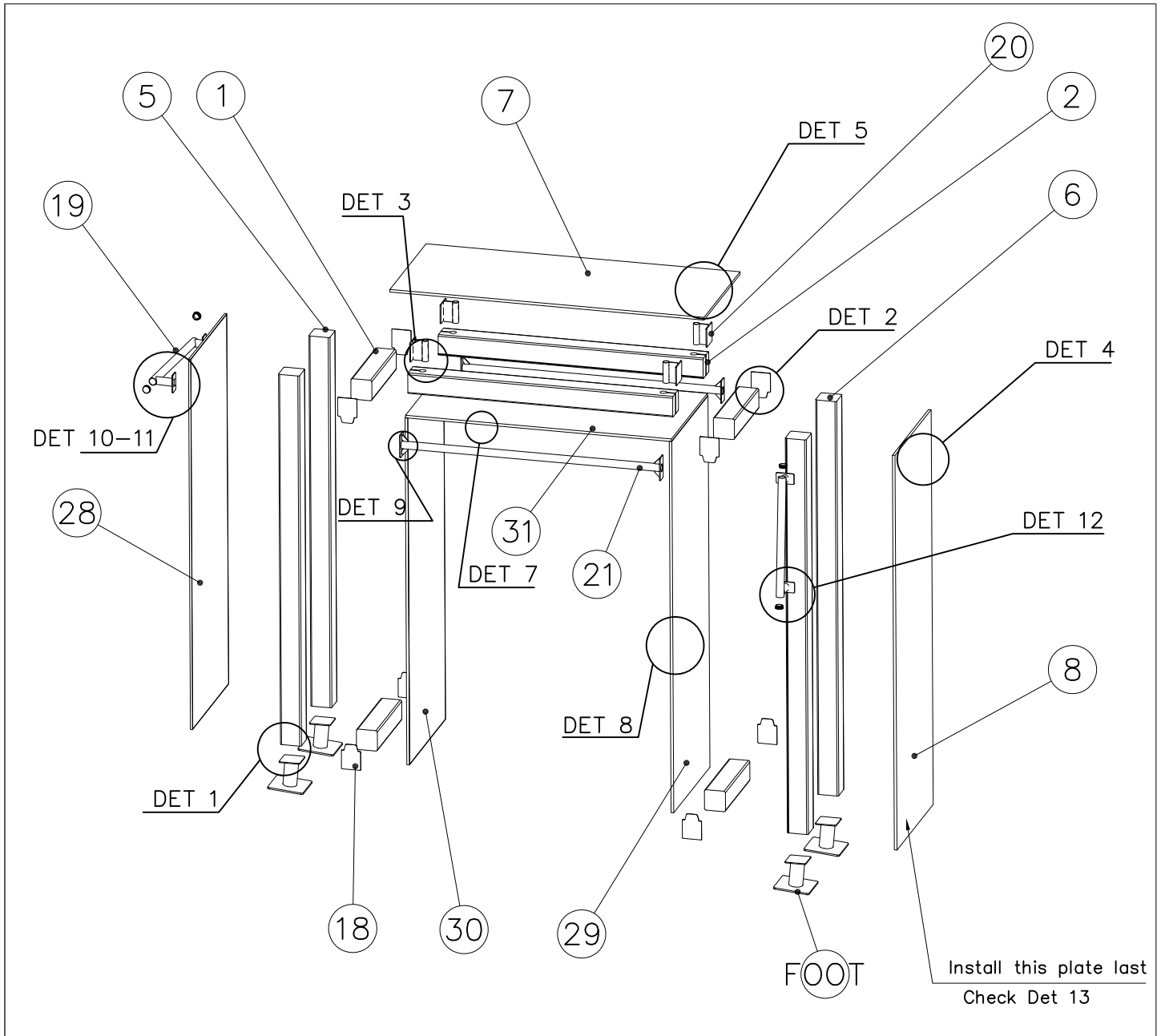

## DET 13

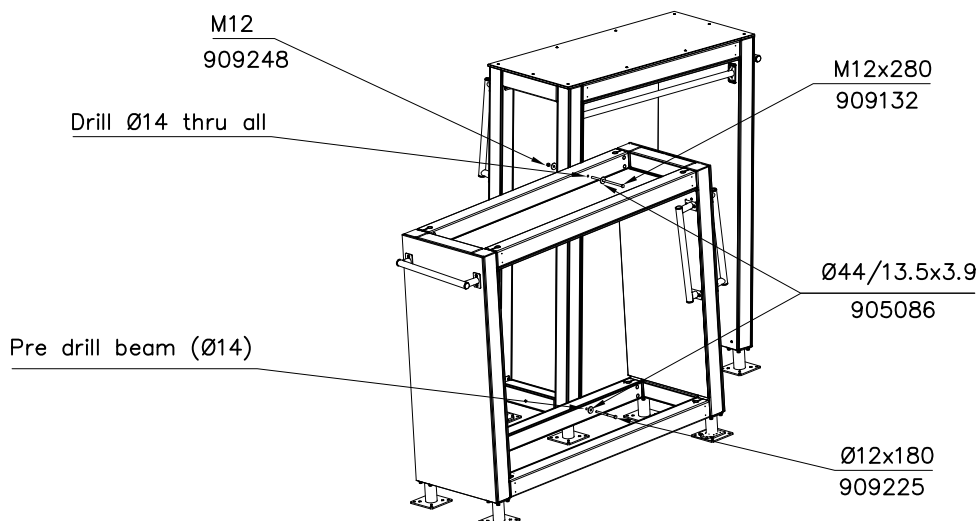

# WINAM GROUP

## SURF. FOUNDATION

# 709261

DATE: 15.8.2019

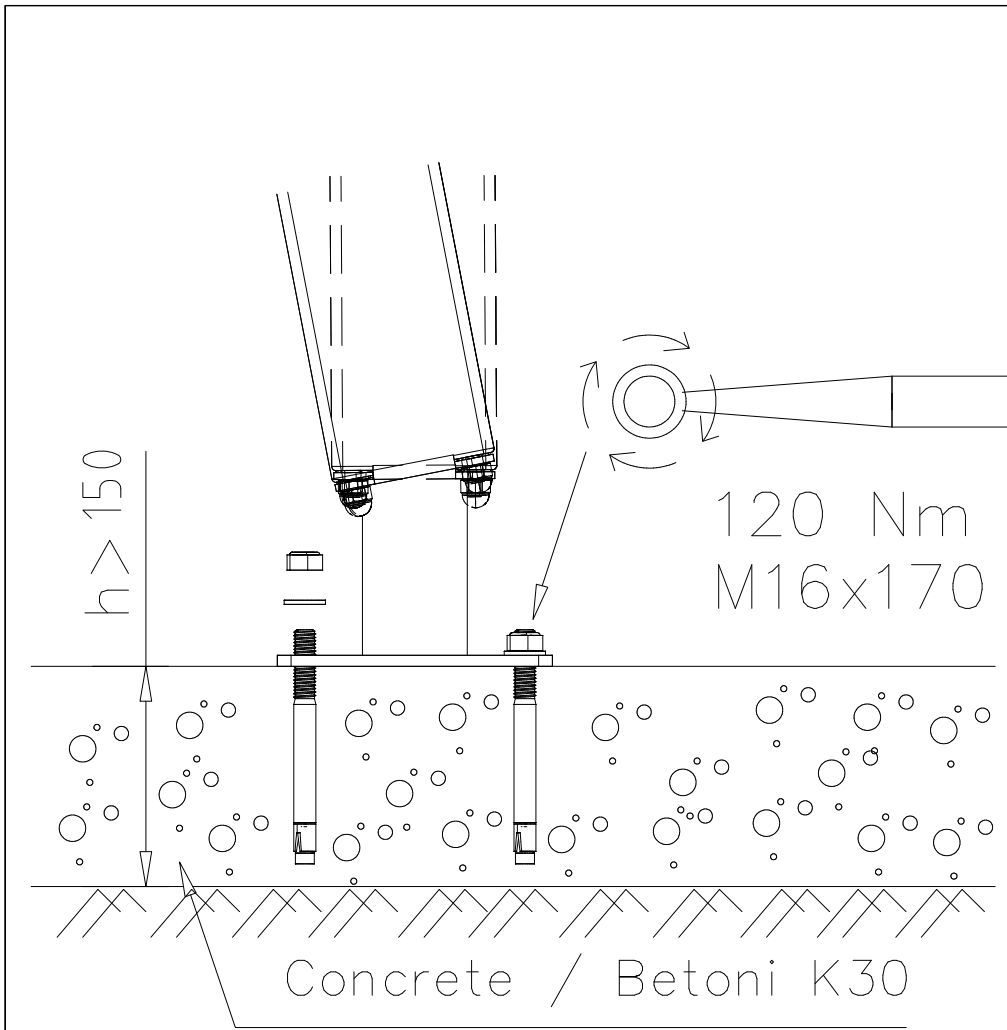

① 904450	PCS	② 905104	PCS
	4		4
M16x170		M10	
	PCS		PCS
	PCS		PCS
○ 910267	PCS	○ 910330	PCS
	1		2
152x200x200		152x200x200	
	PCS		PCS

Ø16 ↓ > 130

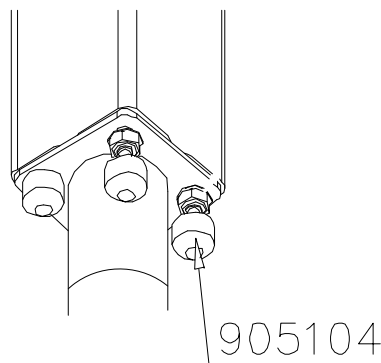
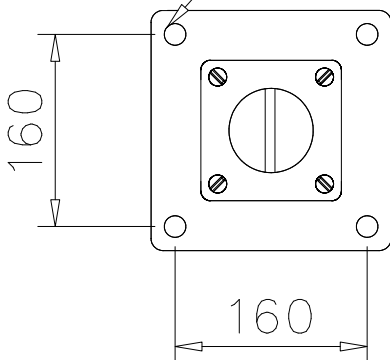

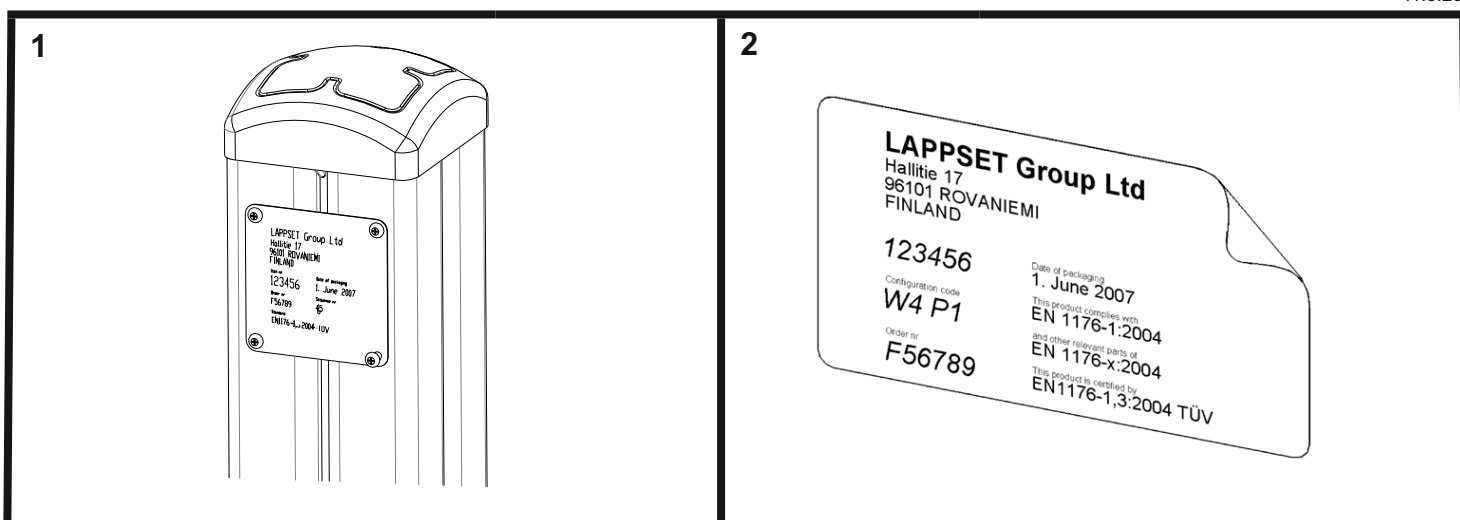

### Tuotekyltti tulee tuotteen mukana yhdellä seuraavista tavoista:

#### 1) Metallinen tuotekyltti ja kiinnitysruuvit

- Kiinnitä tuotekyltti ruuveilla tolppaan noin 2 metrin korkeuteen kuvan 2 mukaisesti.

#### 2) Tuotekylttitarra

- Puhdista maalattu metalli- tai vaneripinta pölystä ja kosteudesta. Liimaa tarra kuvan 3 mukaisesti.
- Huom. Älä kiinnitä tarraa karheapintaiseen laminaattiin tai maalattuun puuhun.

### Vår produktmärkning levereras på ett av följande sätt:

#### 1) Produktskylt i metall

- Fäst skylten med de medföljande skruvarna

#### 2) Självhäftande produktetikett

- Rengör den pulverlackerad metallytan eller laminatytans åttanblirfrifrånsmutsochfukt. Fäst etiketten enligt fig. 3.
- Obs! Fäst ej etiketten på detaljer med skrovlig yta eller på målat trä.

### Product label is delivered by one of following ways:

#### 1) Metal product label and screws

- Fasten the label with screws.

#### 2) Label sticker

- Clean the painted metal or plywood surface from dirt and moisture. Fasten the sticker as shown in the figure 3.
- Note. Do not attach the sticker to rough surfaced laminate or painted wood.

### La plaque d'informations produit est livrée sous l'une de ces 3 formes :

#### 1) Plaque métallique et vis

- Fixez la plaque à l'aide des vis.

#### 2) Etiquette autocollante

- Avant de coller l'étiquette, nettoyez le composant métallique peint ou la plaque de contreplaqué, de toute saleté. La surface doit être sèche (voir image 3).
- Attention, ne pas coller l'étiquette sur une surface lamellé-collée irrégulière ou sur du bois peint.

### Die Auslieferung des Produktaufklebers erfolgt auf eine dieser Arten:

#### 1) Produkt-Schild aus Metall incl. Schrauben

- Die Befestigung des Schildes erfolgt mittels der Schrauben.

#### 2) Aufkleber

- Entfernen Sie zunächst Schmutz und Feuchtigkeit vom lackierten Metall bzw. von der Holzoberfläche und bringen Sie den Aufkleber wie im Bild oben rechts beschrieben auf den gesäuberten Untergrund auf.
- Beachten Sie: Bringen Sie den Aufkleber nicht auf raues laminiertes oder lackiertes Holz an.