

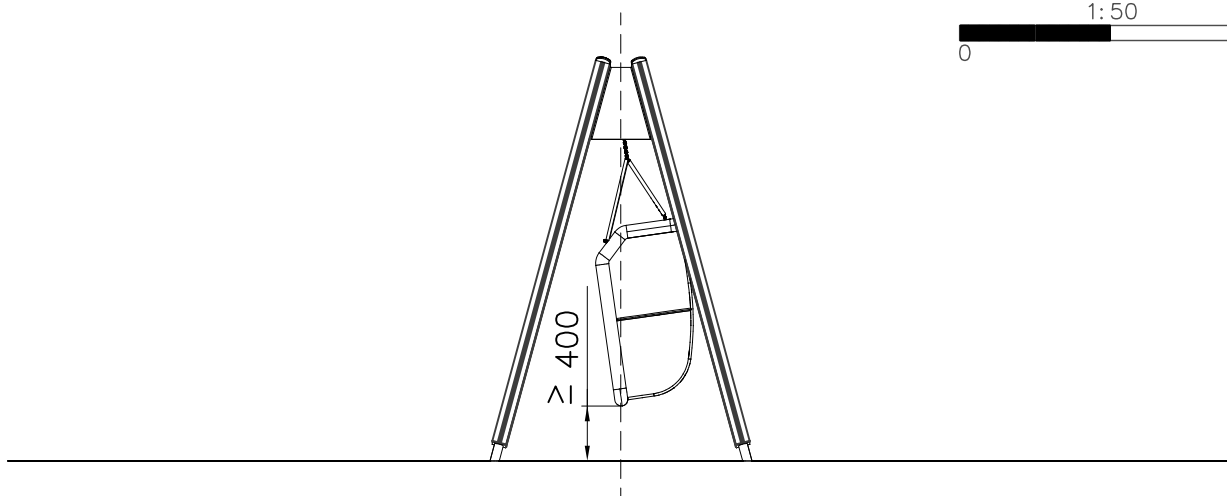

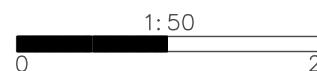

EN Impact Area 21.1 m<sup>2</sup>  
Falling space 21.1 m<sup>2</sup>  
Max falling height 1400 mm.

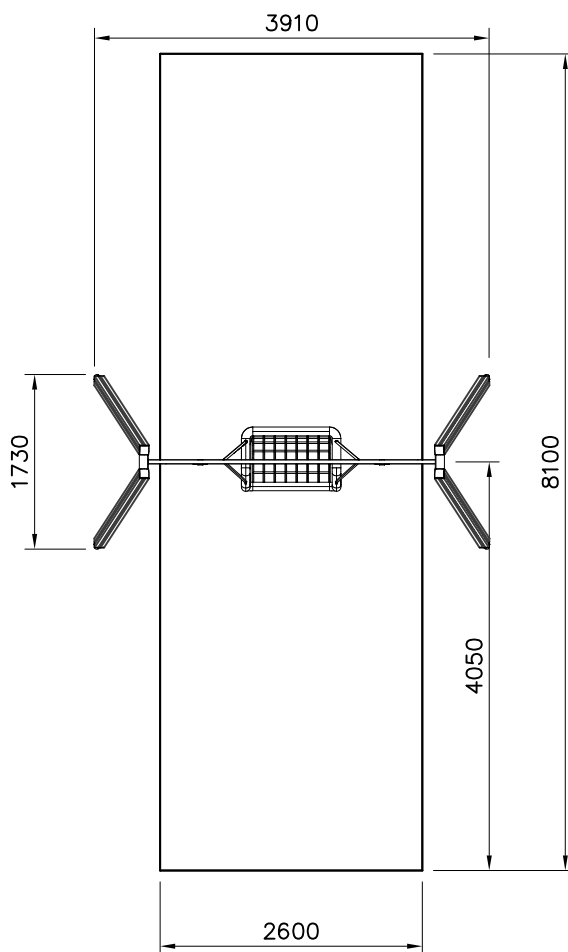
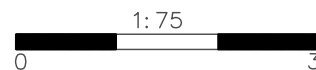
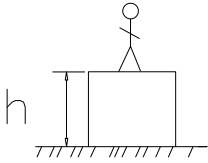

												
<p><b><math>h &lt; 600</math></b></p> <p>Without movement and therefore without Impact Area</p>	<p>Totally hard surfaces.</p> <p>Note. Lappset does <u>not</u> recommend totally hard surfaces at all.</p>	<p>E.g. concrete or asphalt</p> 										
<p><b><math>h &lt; 600</math></b></p> <p>With movement e.g. rocking</p>	<p>Materials with very limited impact attenuating properties.</p>	<p>E.g. wood</p> 										
<p><b><math>h &lt; 1000</math></b></p>	<p>Materials with significant impact attenuating properties.</p>	<p>fine gravel 0–8 mm</p>  <p>grass</p>  <p>unsorted sand</p> 										
<p><b><math>h &lt; 3000</math></b></p>	<p>Loose fill material</p> <p>E.g. sand/gravel 0,25...8 mm D60/D10&lt;3,0 Woodchips 5...30 mm bark 20...80 mm</p>	 <table data-bbox="1021 1691 1324 1792"> <tr> <td><math>\underline{S}</math></td> <td><math>\underline{h}</math></td> </tr> <tr> <td>30 cm</td> <td>&lt; 2,0 m</td> </tr> <tr> <td>40 cm</td> <td>&lt; 3,0 m</td> </tr> </table>	$\underline{S}$	$\underline{h}$	30 cm	< 2,0 m	40 cm	< 3,0 m				
$\underline{S}$	$\underline{h}$											
30 cm	< 2,0 m											
40 cm	< 3,0 m											
	<p>Syntethic granulates</p> <table data-bbox="399 1892 750 2060"> <tr> <td><math>\underline{S}</math></td> <td><math>\underline{h}</math></td> </tr> <tr> <td>40 mm</td> <td>~&gt; 1,2...1,3 m</td> </tr> <tr> <td>50 mm</td> <td>~&gt; 1,5...1,7 m</td> </tr> <tr> <td>60 mm</td> <td>~&gt; 1,8...2,0 m</td> </tr> <tr> <td>70 mm</td> <td>~&gt; 2,1...2,5 m</td> </tr> </table> <p>Note. For accurate values, see manufacturer's instructions.</p>	$\underline{S}$	$\underline{h}$	40 mm	~> 1,2...1,3 m	50 mm	~> 1,5...1,7 m	60 mm	~> 1,8...2,0 m	70 mm	~> 2,1...2,5 m	
$\underline{S}$	$\underline{h}$											
40 mm	~> 1,2...1,3 m											
50 mm	~> 1,5...1,7 m											
60 mm	~> 1,8...2,0 m											
70 mm	~> 2,1...2,5 m											

REMOVE SAFETY SURFACE/SAND/GRAVEL  
TO CHECK FOUNDATION

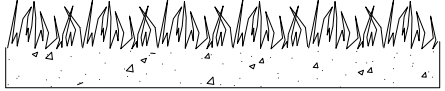
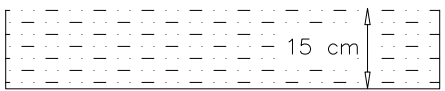
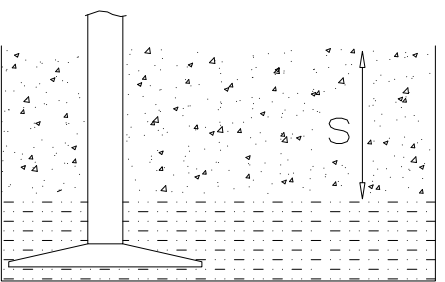
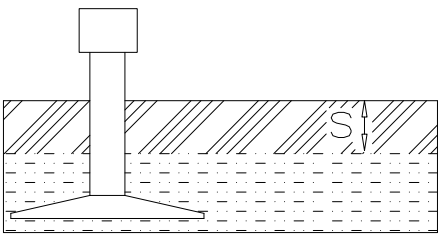
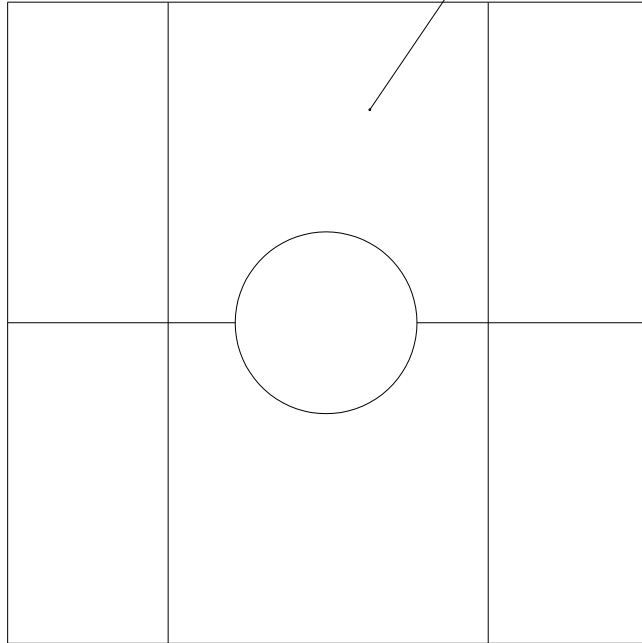



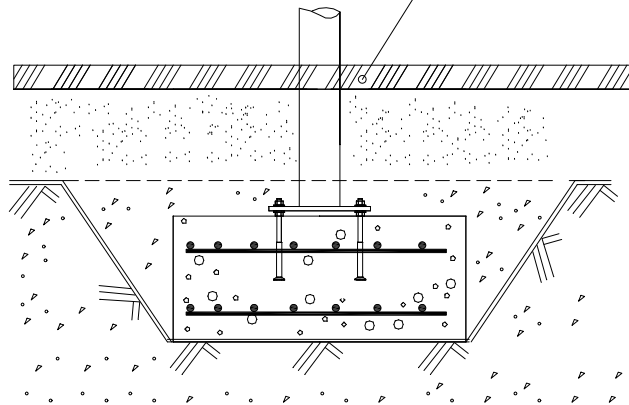

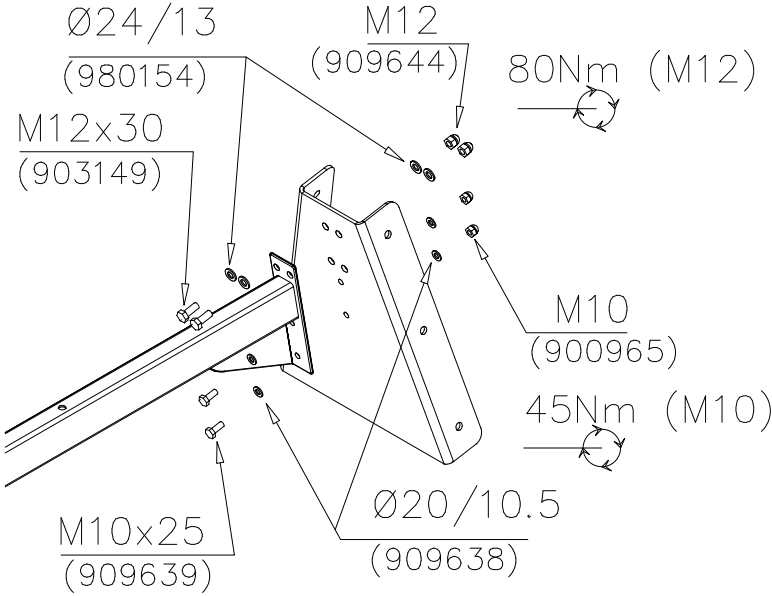
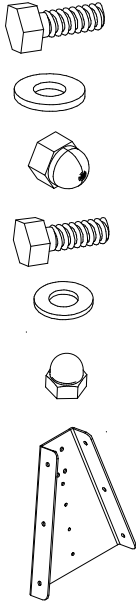
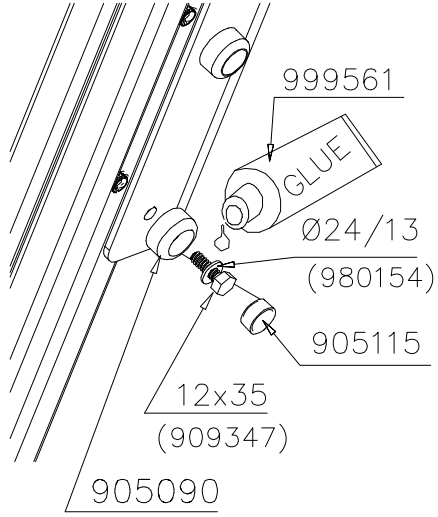
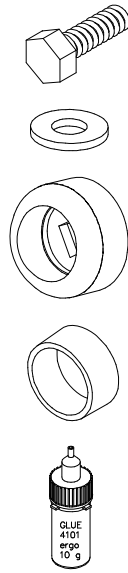
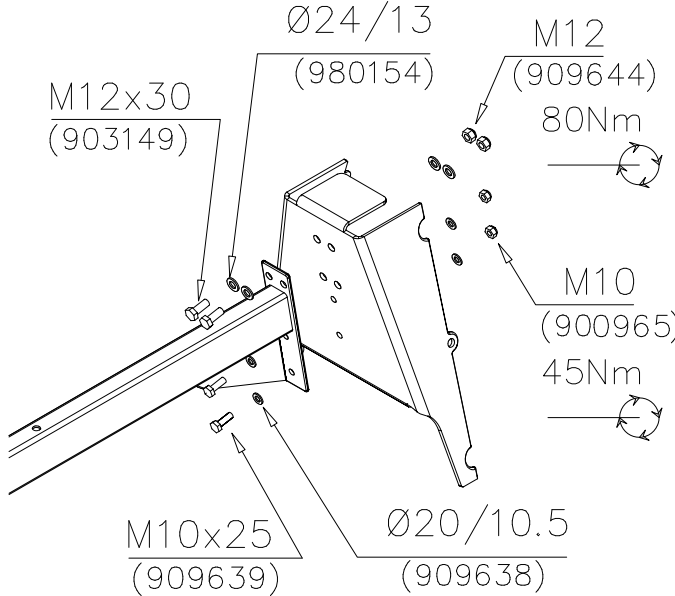
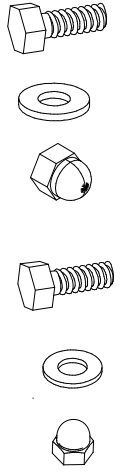

REMOVE SAFETY SURFACE/SAND/GRAVEL  
TO CHECK FOUNDATION

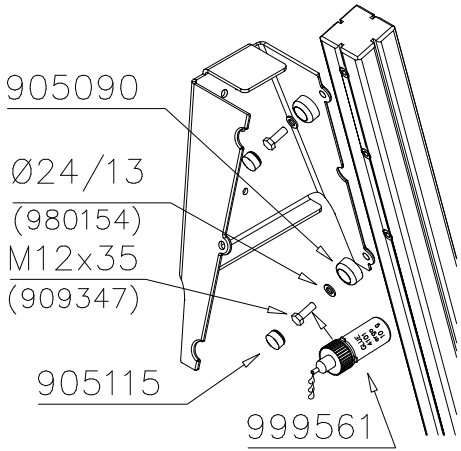

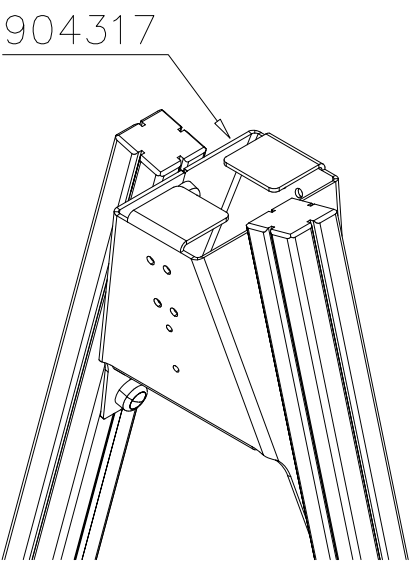
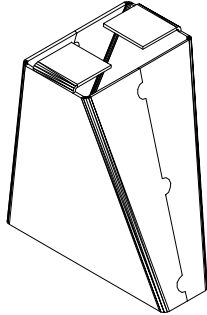
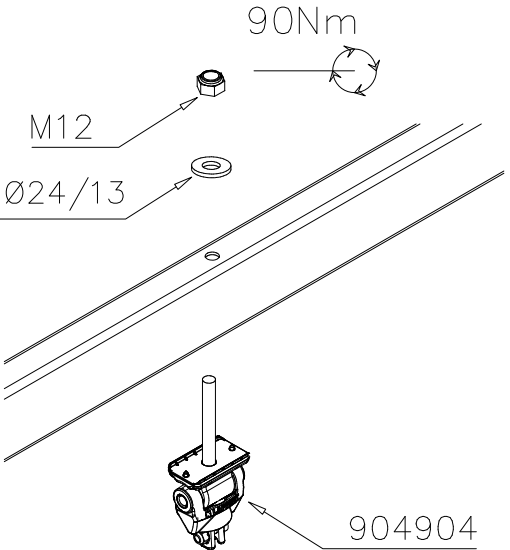
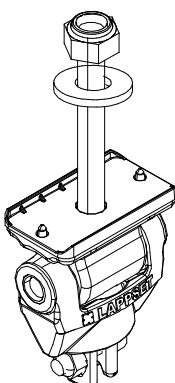

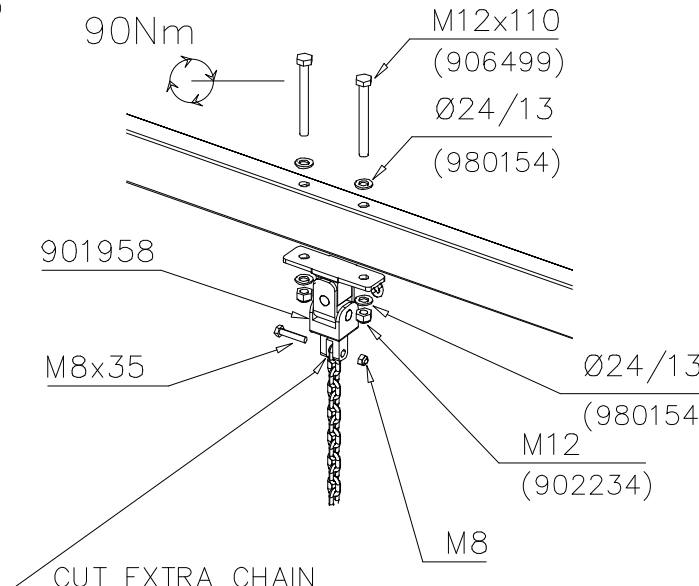
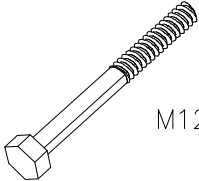
<p>DET A</p>  <p> <math>\varnothing 24/13</math> (980154)  M12x30 (903149)  M12 (909644)  80Nm (M12)  M10 (900965)  45Nm (M10)  M10x25 (909639)  <math>\varnothing 20/10.5</math> (909638) </p>	 <ul style="list-style-type: none"> <li>M12x30 2 pcs</li> <li><math>\varnothing 24/13</math> 4 pcs</li> <li>M12 2 pcs</li> <li>M10x25 2 pcs</li> <li><math>\varnothing 20/10.5</math> 4 pcs</li> <li>M10 2 pcs</li> <li>905991 1 pcs</li> </ul>
<p>DET A</p>  <p> 999561  GLUE  <math>\varnothing 24/13</math> (980154)  905115  12x35 (909347)  905090 </p>	 <ul style="list-style-type: none"> <li>M12x35 6 pcs</li> <li><math>\varnothing 24/13</math> 6 pcs</li> <li><math>\varnothing 45</math> 6 pcs</li> <li><math>\varnothing 30</math> 6 pcs</li> <li>GLUE</li> </ul>
<p>DET B</p>  <p> <math>\varnothing 24/13</math> (980154)  M12x30 (903149)  M12 (909644)  80Nm  M10 (900965)  45Nm  M10x25 (909639)  <math>\varnothing 20/10.5</math> (909638) </p>	 <ul style="list-style-type: none"> <li>M12x30 2 pcs</li> <li><math>\varnothing 24/13</math> 4 pcs</li> <li>M12 2 pcs</li> <li>M10x25 2 pcs</li> <li><math>\varnothing 20/10.5</math> 4 pcs</li> <li>M10 2 pcs</li> </ul>

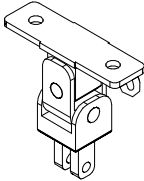
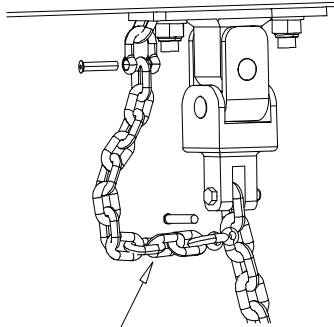
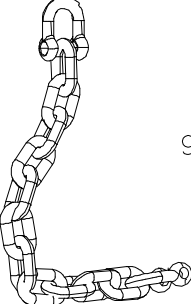
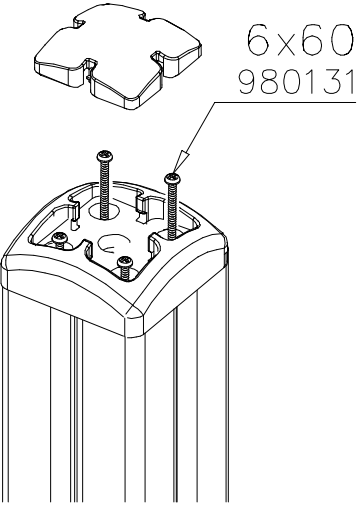
<p>DET B</p> 	
<p>DET B</p> 	 <p>904317</p>
<p>DET C</p> 	 <p>904904</p>

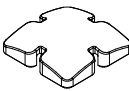
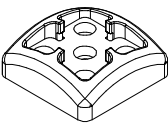
<p>DET D</p>  <p>90Nm</p> <p>M12x110 (906499)</p> <p>Ø24/13 (980154)</p> <p>901958</p> <p>M8x35</p> <p>Ø24/13 (980154)</p> <p>M12 (902234)</p> <p>M8</p> <p>CUT EXTRA CHAIN</p>	 <p>M12x110 2 pcs</p>  <p>Ø24/13 4 pcs</p>  <p>M12 2 pcs</p>  <p>901958 1 pcs</p>
<p>DET D</p>  <p>903577</p>	 <p>903577 1 pcs</p>
<p>DET E</p>  <p>6x60 980131</p>	 <p>980131 4 pcs</p>  <p>905138 1 pcs</p>  <p>905196 1 pcs</p>

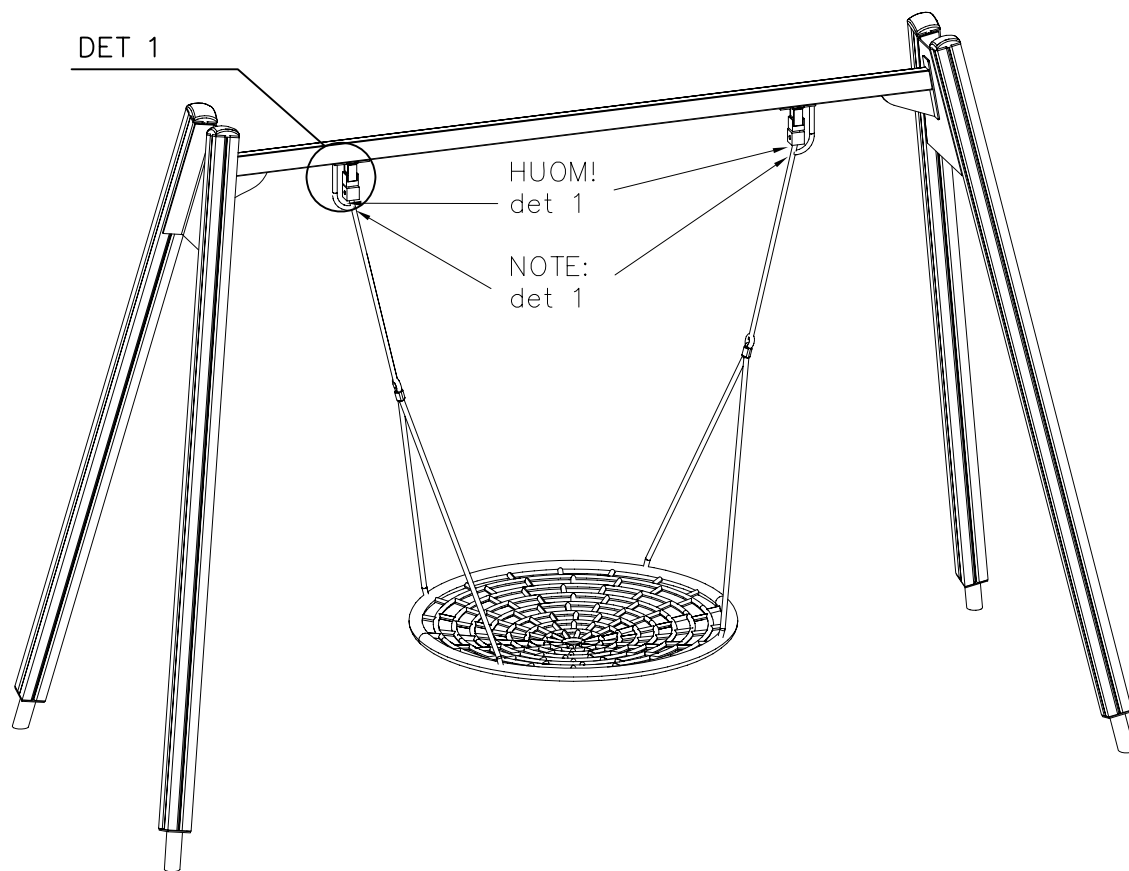

DET 1

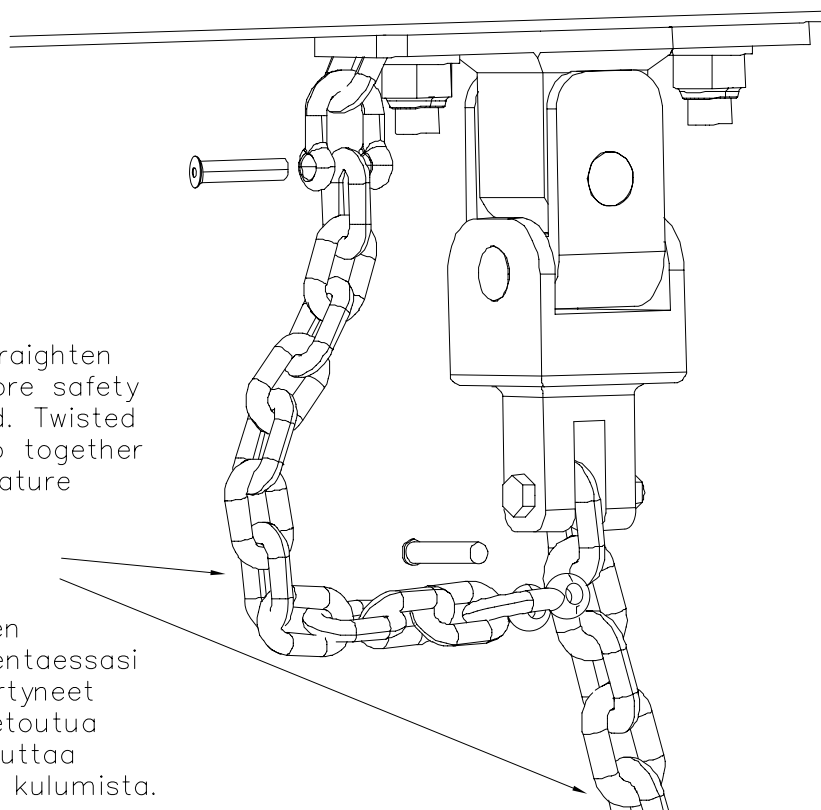

Note:  
Make sure to straighten  
both chains before safety  
chain is installed. Twisted  
chains may wrap together  
and cause premature  
wear.

Huom!  
Varmistu ketjujen  
suoruudesta asentaessasi  
turvaketjua. Kiertyneet  
ketjut voivat kietoutua  
toisiinsa ja aiheuttaa  
ketjujen nopeaa kulumista.

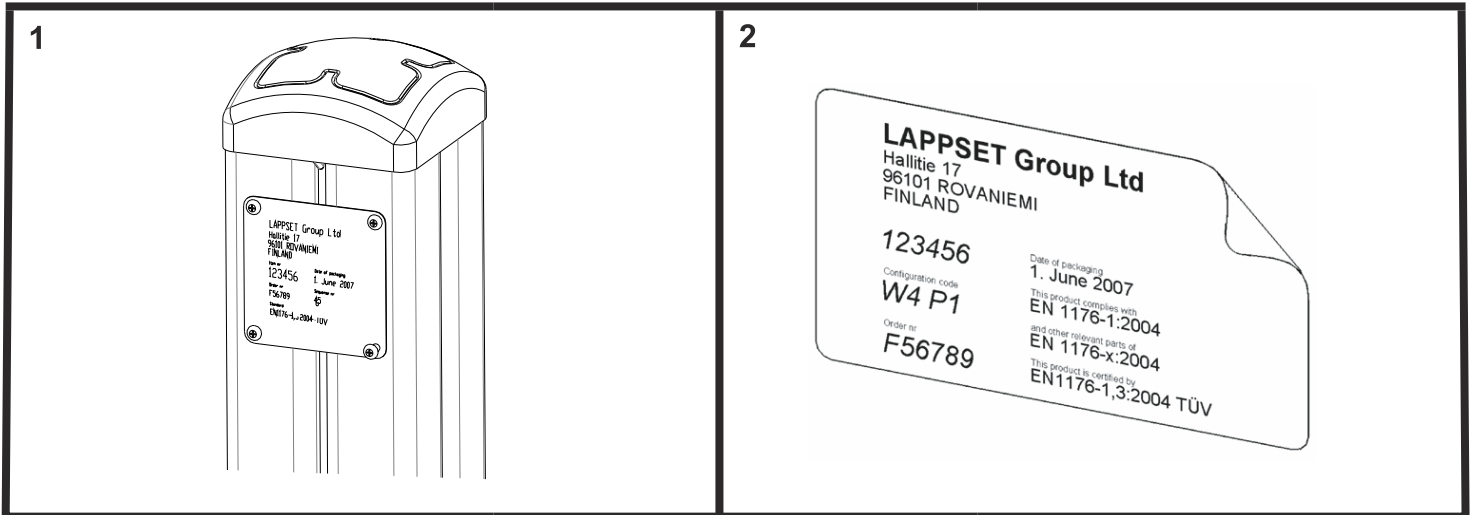

**Tuotekyltti tulee tuotteen mukana yhdellä seuraavista tavoista:**

**1) Metallinen tuotekyltti ja kiinnitysruuvit**

- Kiinnitä tuotekyltti ruuveilla tolppaan noin 2 metrin korkeuteen kuvan 1 mukaisesti.

**2) Tuotekylttitarra**

- Puhdista maalattu metalli- tai vaneripinta pölystä ja kosteudesta. Liimaa tarra kuvan 2 mukaisesti.
- Huom. Älä kiinnitä tarraa karheapintaiseen laminaattiin tai maalattuun puuhun.

**Vår produktmärkning levereras på ett av följande sätt:**

**1) Produktskylt i metall**

- Fäst skylten med de medföljande skruvarna

**2) Självhäftande produktetikett**

- Rengör den pulverlackerade metallytan eller laminatyten så att den blir fri från smuts och fukt. Fäst etiketten enligt fig. 2.
- Obs! Fäst ej etiketten på detaljer med skrovlig yta eller på målat trä.

**Product label is delivered by one of following ways:**

**1) Metal product label and screws**

- Fasten the label with screws.

**2) Label sticker**

- Clean the painted metal or plywood surface from dirt and moisture. Fasten the sticker as shown in the figure 2.
- Note. Do not attach the sticker to rough surfaced laminate or painted wood.

**La plaque d'informations produit est livrée sous l'une de ces 3 formes :**

**1) Plaque métallique et vis**

- Fixez la plaque à l'aide des vis.

**2) Etiquette autocollante**

- Avant de coller l'étiquette, nettoyez le composant métallique peint ou la plaque de contreplaqué, de toute saleté. La surface doit être sèche (voir image 2).
- Attention, ne pas coller l'étiquette sur une surface lamellé-collée irrégulière ou sur du bois peint.

**Die Auslieferung des Produktaufklebers erfolgt auf eine dieser Arten:**

**1) Produkt-Schild aus Metall incl. Schrauben**

- Die Befestigung des Schildes erfolgt mittels der Schrauben.

**2) Aufkleber**

- Entfernen Sie zunächst Schmutz und Feuchtigkeit vom lackierten Metall bzw. von der Holzoberfläche und bringen Sie den Aufkleber wie im Bild oben rechts beschrieben auf den gesäuberten Untergrund auf.
- Beachten Sie: Bringen Sie den Aufkleber nicht auf raues laminiertes oder lackiertes Holz an.