

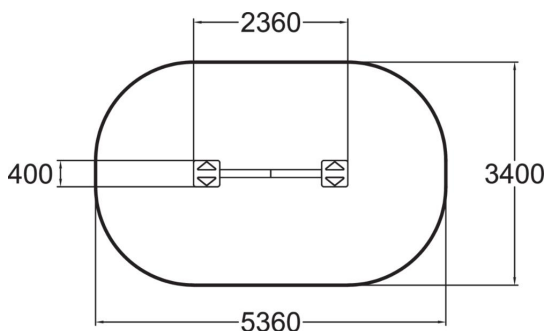

Shaker is a balancing equipment which is very suitable for school yards or parks. It challenges the balance, swaying from side to side.



User age	2+
Number of users	4
Product length, mm	2360
Product width, mm	400
Product height, mm	305
Impact area, m ²	17.4
Falling space, m ²	17.4
Height required, mm	2105
Max. free fall height, mm	600
Safety info	EN 1176-1, (6) TÜV
Installation time (for 1), H	1.5
Foundation options	deep_mounting surface_mounting
Colour of walls and HPL	