

WINAM GROUP

150200M

Apollo

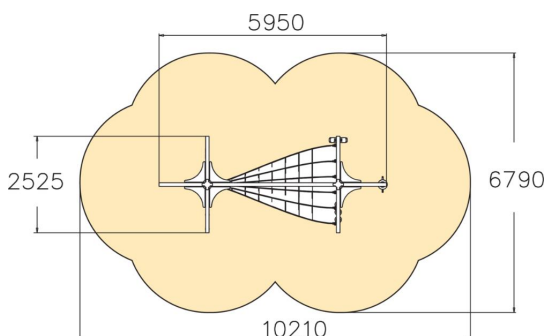
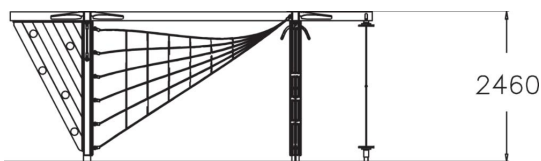
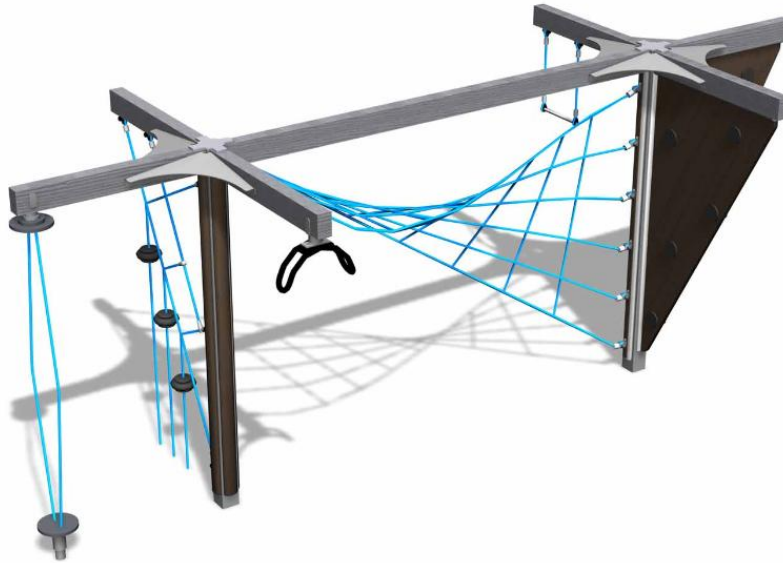

User age	4+
Number of users	18
Product length, mm	5950
Product width, mm	2525
Product height, mm	2460
Impact area, m ²	54.3
Falling space, m ²	54.3
Height required, mm	4000
Max. free fall height, mm	2450
Safety info	EN 1176-1, (11) TÜV
Installation time (for 1), H	20
Foundation options	Deep mounting Surface mounting
Wood	