



# WINAM GROUP

220110

Neon



-  Climbing  
1
-  Slides  
1
-  Towers  
1

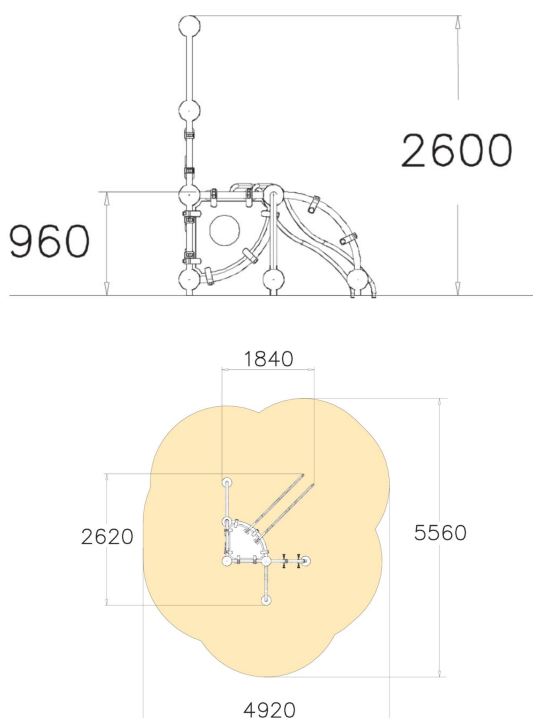

User age	4
Number of users	6
Product length, mm	1840
Product width, mm	2620
Product height, mm	2600
Impact area, m <sup>2</sup>	21.7
Height required, mm	2760
Max. free fall height, mm	1740
Safety info	EN 1176-1, (3):2008 TÜV
Installation time (for 1), H	8
Foundation options	Deep mounting Surface mounting